

LIMITED WARRANTY

COMPANY NAME: _____

COMPANY ADDRESS: _____

CITY: _____ STATE: _____ ZIP: _____

MODEL: _____

SERIAL NUMBER: _____

DATE PURCHASED: _____

DEALER NAME: _____

DATE WARRANTY CARD RETURNED: _____

VIA: _____ WEBSITE _____ MAIL

FORCE UNLIMITED LLC



FORCE UNLIMITED LLC LIMITED WARRANTY

FORCE Unlimited LLC has manufactured or is distributing the Product or Parts to which this warranty is attached. It warrants that the Product or Parts will, under normal conditions of use and service, be free from material defects due to faulty manufacturing for a period of twelve (12) months from the date of delivery to the original user. If any Product or Part does not conform to this warranty, your Dealer will, at its option, repair or replace parts provided, and you will pay all labor costs and costs for materials other than warranty parts. If Product or Part is defective in materials or workmanship, you must promptly notify your Dealer and return to FORCE Unlimited or fax to 319-283-3086 the warranty registration card within 30 days from the date of delivery to original user. The installation of any Part that did not originate from FORCE Unlimited will void this limited warranty in its entirety. In the event of repair or replacement, the warranty period shall not be extended beyond the original warranty period.

If you fail to return the warranty registration card (in parts manual) to FORCE Unlimited within thirty (30) days after the date of delivery, this warranty shall not apply and your remedy for any defects in the Product will be your responsibility.

The above warranty does not cover:

- a. Product that is damaged by abuse, neglect, accident, or modification
- b. Fluids, towing, telephone, travel, loss of vehicle, inconvenience
- c. The product itself if parts are installed on the equipment that did not originate from FORCE Unlimited

The above warranty does not apply under the following conditions:

- a. When Product has been improperly used or installed, modified, or fails because of defects or inefficiency of components not furnished with the Product
- b. When Product is used for purposes for which it was not originally designed or intended, or is used under abnormal operating conditions
- c. When the Dealer or end-user fails to follow FORCE Unlimited instructions regarding the Product

This warranty is extended only to the original user and is not transferable. In the event of a warranty claim, you should promptly notify your Dealer and provide the following:

- a. Model & serial number of the Product
- b. Date of delivery to the original user
- c. Part number of the defective Part
- d. Description of the claim encountered

FORCE Unlimited LLC will bear no other expense including labor and material costs, other than those specified above. Unless modified in writing and signed by both parties, this Limited Warranty is understood to be the complete and exclusive agreement between the parties. No third party has authority to change or modify this warranty in any aspect.

LIMITED WARRANTY

2 YRS

SHELL STRUCTURE, SPINNER FRAME (including inferior welds & cracking)
CONVEYOR GEARBOX (including gears, bearings & seals)

1 YR

SPINNER MOTORS & ADAPTERS (including bearings & seals)
CONVEYOR MOTORS (including bearings & seals)
VALVE MOTORS & CARTRIDGES
CONVEYOR CHAIN – BELT & FASTENERS
CONVEYOR SPROCKETS & BEARINGS
FAN & CONVEYOR RATE SENSORS

WEAR ITEMS

SPINNER FINS
SPINNER DISCS

**MANUFACTURER HAS THE RIGHT TO REPLACE DEFECTIVE OR DAMAGED PARTS
WITH NEW OR REBUILT AT ITS OWN DISCRETION**

PARTS DAMAGED FROM ABUSE OR IMPROPER MAINTENANCE NOT COVERED

FORCE UNLTD. SPREADERS*GPS EQUIPMENT*CONVEYORS

<u>ITEM</u>	<u>PAGE NO.</u>
Conveyor Drive	1
Conveyor Idler	2
Spinner Assembly w/Deflectors	3
Jack Shaft Assembly	5
Spinner Guards & Material Flow Divider	6
Spinner/Conveyor Drive Hydraulics	8
Front Trailer Hydraulics	8.1
Main Valve Block Assembly	10
Inverted "V" & Cross Brace Assembly	14
Sensor Wiring Harness	15
John Deere AN304173 Electrical Harness Adapter Kit	15.1
Decals	16
Gear Box	17
Belt Over Pintle Chain	18
Feedgate Assembly	19
Swinging Endgate & Feedgate Assembly	19.1
Swinging Endgate Catch/Release Assembly	19.2
Hillside Flow Divider	20
Hydraulic Pipes	21
Chain Shields	22
Light Options	23
Front Belt Sealer	24
#2 Straight Chain	26
Hydraulic Swinging Endgate	30
Trailer Hydraulic Brakes	31
Safety Decals	35
Trailer Decals	35.1
Optional 12" High SS Box Extensions	36

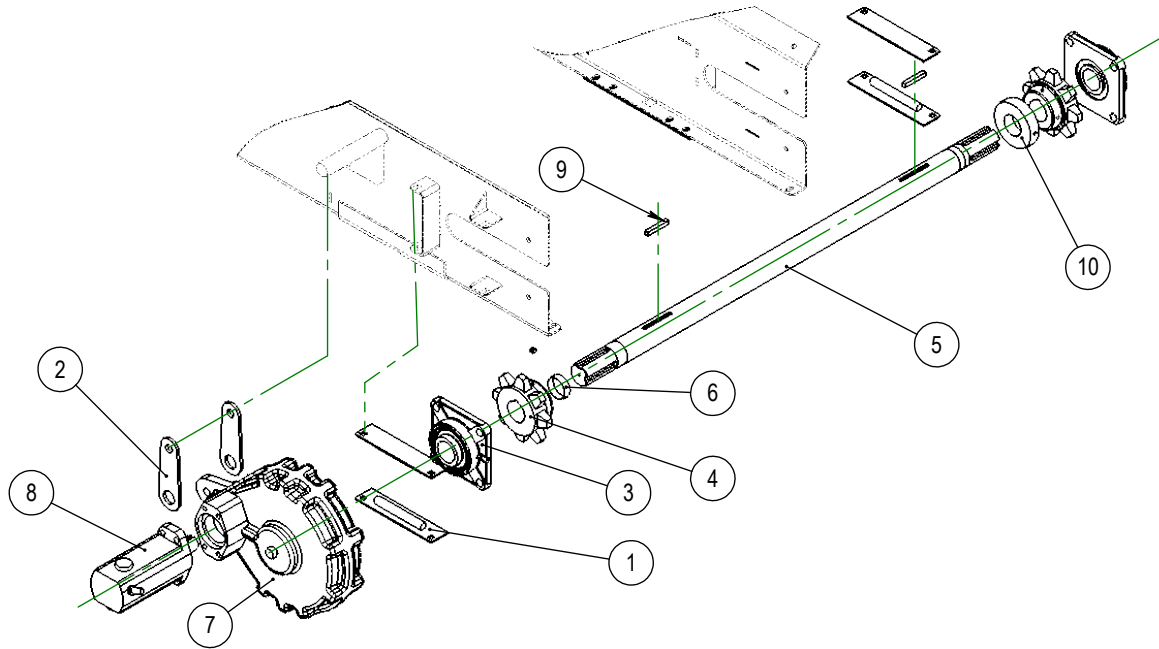

CONVEYOR DRIVE

ITEM	PART NO.	DESCRIPTION	SINGLE DRIVE QTY	DOUBLE DRIVE QTY
1	50-074 1200-302SS 1209-43 1205-27	Weldment-SS Bearing Slide (2) Carriage Bolts 3/8" UNC x 1" SS / Slide (2) Lock Washer 3/8" SS / Slide (2) Nut - 3/8" UNC SS / slide	4	4
2	FL3024 IA 1200-604SS 1200-302SS	Arm - Idler (1) Hex Head Capscrew - 3/4" UNC x 3" SS / Arm (1) Lock Nut - 3/4" SS / Arm	2	4
3	1217-102	Bearing (2) Set Screw - 3/8"-24 UNF x 3/8" / Bearing	2	2
4	1217-20	Sprocket - Drive (2) Set Screw - 3/8"-16 UNC x 3/8" / Sprocket	2	2
5	FL3424 DS FL3024 DS FL3424 DS-2	Shaft - Single Drive ProForce Shaft - Single Drive AgForce Shaft - Double Drive ProForce	1	1
6	F 99198	Seeve - SS	1	2
7	1220-50	Gearbox (2) Key - Sqr, 1/2" x 2-1/4" / Gearbox	1	2
8	1213-145 1213-18 1213-19 1220-145 1200-403 1209-62 1213-145 SK	Motor - Hydraulic w/Sensor Motor - Hydraulic w/Sensor (Drivers side) Motor - Hydraulic w/o Sensor (Passenger side) (1) Key - Sqr, 5/16" x 1-1/4" / Motor (4) Socket Head Capscrew - 1/2" x 1-1/2" / Motor (4) Lock Washer - 1/2" / Motor Seal Kit	1	1
9	1220-525	Key - Square, 3/8" x 2-1/2"	2	2
10	70-130	Support Roller (1 Required Per Asphalt Unit Only) (1) Set Screw - 3/8" - 16 UNC x 3/8" / Roller		

CONVEYOR IDLER

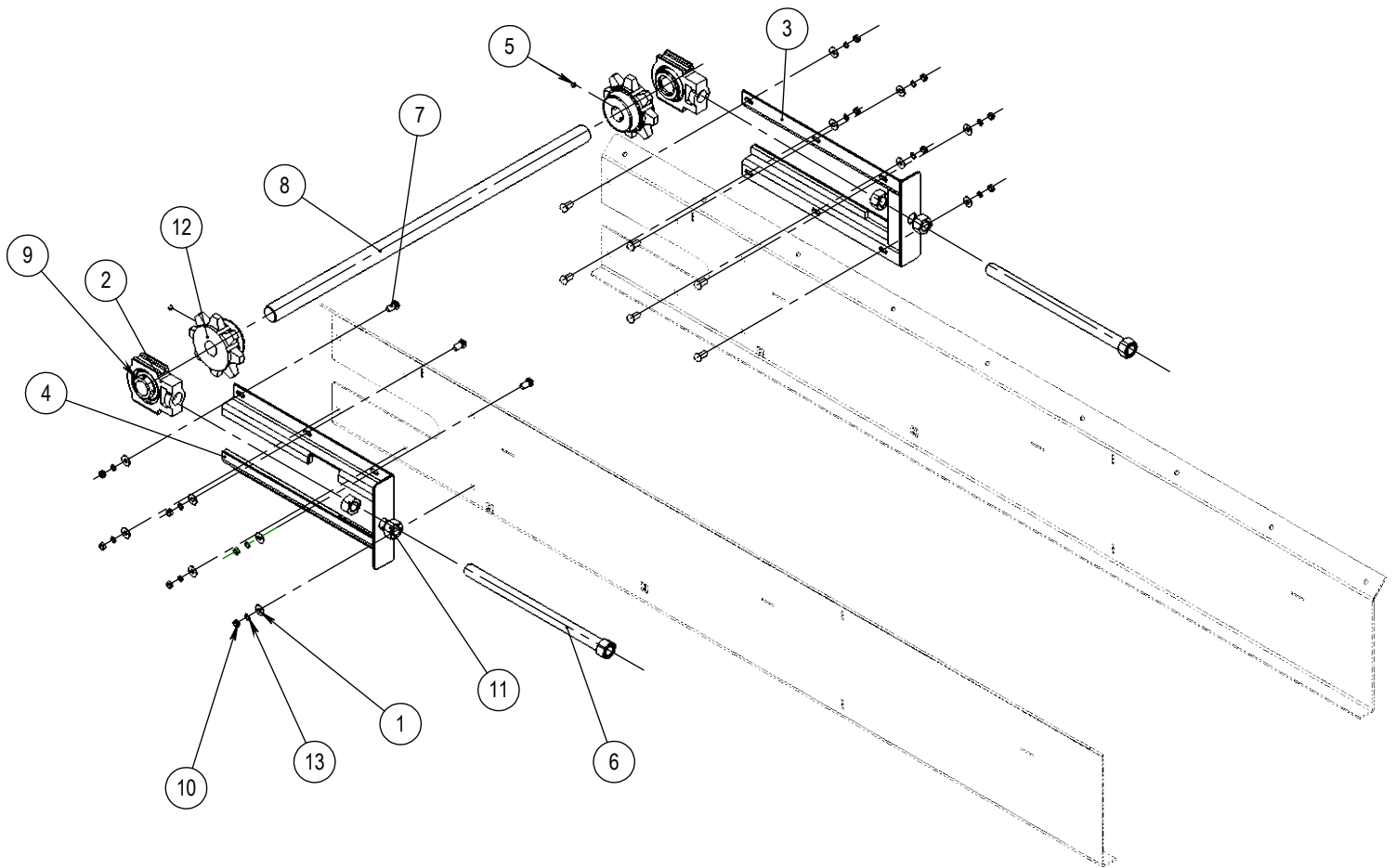

<u>ITEM</u>	<u>PART NO.</u>	<u>DESCRIPTION</u>	<u>QTY</u>
1	1209-40	Flat Washer - 3/8"	12
2	1217-103	Bearing - Take Up	2
3	50-011	RH Take Up	1
4	50-011-L	LH Take Up	1
5		Set Screw - 3/8" UNF x 3/8" Long	4
6	1225-02	Weldment - Take Up Bolt	2
7	1200-302SS	Carriage Bolt - 3/8" UNC x 1" SS	12
8	1220-515	Shaft Idler ProForce	1
	1220-51	Shaft Idler AgForce	
9		Set Screw - 5/16"-24 UNF x 5/16" Long	4
10	1205-27	Nut - 3/8" UNC SS	12
11	1205-79	Nut - 1" UNC	4
12	1217-15	Sprocket - Idler	2
13	1209-43	Lock Washer - 3/8" SS	12

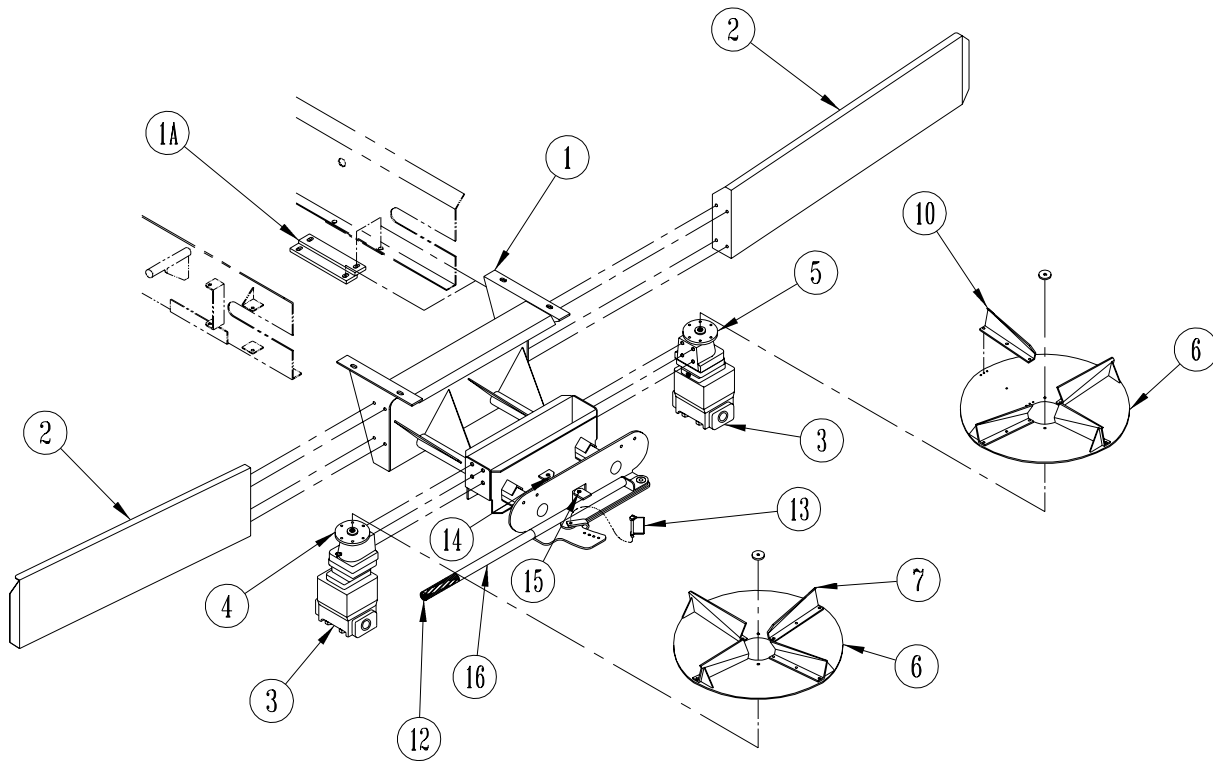

OPTIONAL SPINNER ASSY. WITH DEFLECTORS

ITEM	PART NO.	DESCRIPTION	24" ASSY QTY.	30" ASSY QTY.
1	1234-301	Weldment - 24" Spinner Assembly Requires: (4) Carriage Bolt - 1/2" UNC x 2" SS	1	-
	1200-404	(4) Flat Washer - 1/2" SS		
	1209-61	(4) Lock Washer - 1/2" SS		
	1209-63	(4) Lock Washer - 1/2" SS		
	1205-36	(8) Nut - 1/2" UNC SS		
1 A	1218-15	Adapter - Mounting Requires: Same as 1234-301 (Above)	2	-
1	1236-301	Weldment - 30" Spinner Assembly Requires: Same as 1234-301 (Above)	-	1
2	1234-108	Weldment - SS Deflector (132" OA Fender Width)	1 RH, 1 LH	1 RH, 1 LH
2	1234-108MS	Weldment - MS Deflector (132" OA Fender Width) Requires: (4) Hex Head Capscrew - 3/8" UNC x 1" SS		
	1200-3011	(8) Flat Washer - 3/8" SS		
	1209-41	(4) Lock Washer - 3/8" SS		
	1209-43	(4) Lock Washer - 3/8" SS		
	1205-27	(4) Nut - 3/8" UNC SS		
		Per Deflector		
2	1236-108	Weldment - SS Deflector (96" OA Fender Width)		
2	1236-108MS	Weldment - MS Deflector (96" OA Fender Width) Requires: Same as 1234-108 (Above)		
3	1213-15	Motor - Hydraulic (24" Disc) Requires: (Per Motor) (4) Socket Head Capscrew - 1/2" UNC x 1-1/2"	2	-
	1200-403	(4) Lock Washer - 1/2"		
	1209-62	(1) Key - Square, 5/16" x 1-1/2" Lg.		
	1213-155	Replacement Parts: Seal Kit		
	1213-156	Shaft & Gear Set		
3	1213-206	Motor - Hydraulic (30" Disc) Requires: (Per Motor) (4) Socket Head Capscrew - 1/2" UNC x 1-1/2"	-	2
	1200-403	(4) Lock Washer - 1/2"		
	1209-62	(1) Key - Square, 5/16" x 1-1/2" Lg.		
	1213-155	Replacement Parts: Seal Kit		
	1213-145 SK			
4	1218-73	Assembly - Jack Shaft with Sensor Mount (24" Disc) Requires: (1) Hex Head Capscrew - 1/2" UNC x 1" SS	1	-
	1200-400SS	(1) Washer - 1/2" SS		
	1209-61	(4) Hex Head Capscrew - 1/2" UNC x 1-1/4" SS		
	1200-4011	(4) Lock Washer - 1/2" SS		
	1209-63			
4	1218-732M	Assembly - Jack Shaft with Sensor Mount (30" Disc) Requires: Same as 1218-73 (Above)	-	1

FORCE UNLTD. SPREADERS*GPS EQUIPMENT*CONVEYORS

ITEM	PART NO.	DESCRIPTION	24" ASSY QTY	30" ASSY QTY
5	1218-72	Assembly - Jack Shaft without Sensor Mount (24" Disc) Requires: (1) Hex Head Capscrew - 1/2" UNC x 1" SS	1	-
	1200-400SS	(1) Washer - 1/2" SS		
	1209-61	(4) Hex Head Capscrew - 1/2" UNC x 1-1/4" SS		
	1200-4011	(4) Lock Washer - 1/2" SS		
5	1218-722M	Assembly - Jack Shaft without Sensor Mount (30" Disc) Requires: Same as 1218-72 (Above)	-	1
6	1218-750	Universal 24" Disc - Dished Requires: (6) Hex Head Capscrew - 1/4" UNC x 1" MS	2	-
	1200-203	(6) Top Lock Nut - 1/4"		
	1205-10	Per Disc		
6	1218-350	Universal 30" Disc - Dished Requires: (6) Hex Head Capscrew - 5/16" UNC x 1-1/4" MS	-	2
	1200-252	(6) Top Lock Nut - 5/16"		
	1205-17	Per Disc		
7	1218-71	Weldment - Fin, Left Hand Requires: Hex Head Capscrew - 5/16" UNC x 3/4" MS	4	6
	1200-250	Hex Head Capscrew - 5/16" UNC x 1" MS	3 Per Fin	3 Per Fin
	1200-251	Top Lock Nut - 5/16"	3 Per Fin	3 Per Fin
	1205-17			
10	1218-70	Weldment - Fin, Right Hand Requires: Hex Head Capscrew - 5/16" UNC x 3/4" MS	4	6
	1200-250	Hex Head Capscrew - 5/16" UNC x 1" MS	3 Per Fin	3 Per Fin
	1200-251	Top Lock Nut - 5/16"	3 Per Fin	3 Per Fin
	1205-17			
12	1218-01	Grip - Foam	1	1
13	1218-04	Adjusting - Safety Snap Pin	1	1
14	1225-01	Threaded Rod - Fine, 1/2" x 3" Lg., SS Requires: (2) Nut - Hex 1/2" UNF MS	1	1
	1205-38			
15	1218-02	Rod End - Ball Joint, SS Requires: (1) Flat Washer - 1/2" SS	2	2
	1209-61	(1) Lock Nut - Nylon Insert, Thin 1/2" UNC SS		
	1205-39	(1) Hex Head Capscrew - 1/2" UNC x 1-1/2" SS		
	1200-350	Per Rod End		
16	1218-03	Weldment - Adjusting Handle Requires: (1) Washer - Oversized	1	1
	1218-06	(1) Hex Head Capscrew - 1/2" UNC x 1-1/2" SS		
	1200-350	(1) Lock Nut - Nylon Insert, Thin 1/2" UNC SS		
	1205-39			

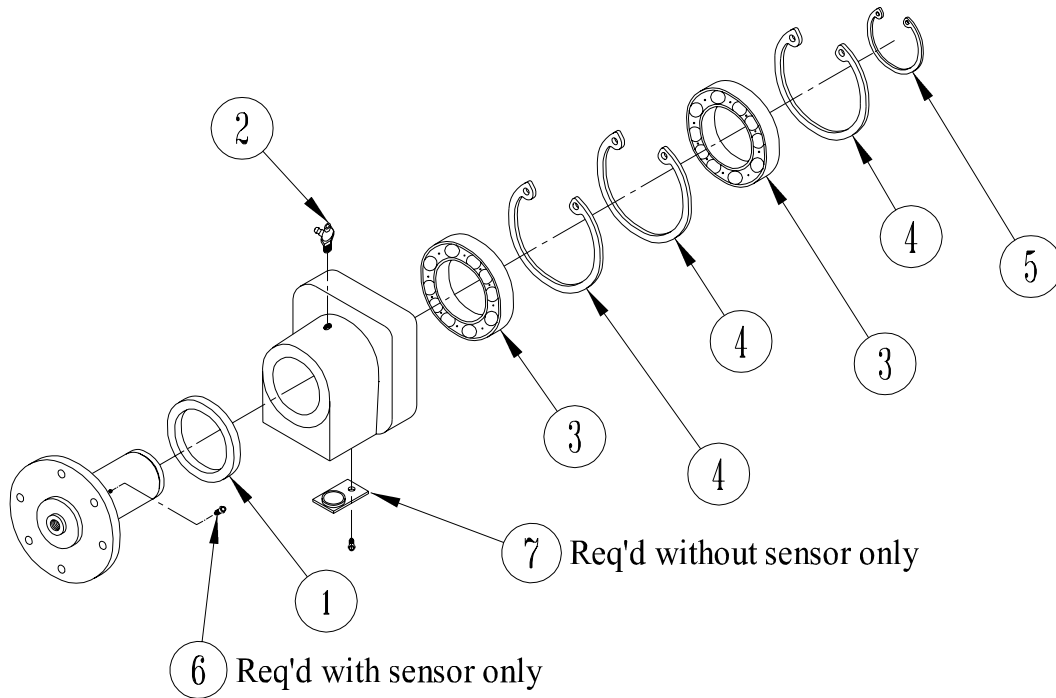

JACK SHAFT ASSEMBLY

ITEM	PART NO.	DESCRIPTION	24" ASSY QTY.	30" ASSY QTY.
1	1204-06	Seal - Oil	1	1
2	1204-02	Fitting - Grease	1	1
3	1217-104	Bearing - Ball	2	2
4	1208-05	Snap Ring - Internal	3	3
5	1208-06	Snap Ring - External	1	1
6	1200-245	Cap Screw - Socket Head 10-24 x 1/4"	4	4
7	1218-735	Kit - Sensor Hole Plug Includes: (1) Plug Plate (1) O-ring (1) Screw - 1/4-20 x 1/2" SS Philips Pan Head	As Req'd	As Req'd
	1218-72	Assembly - Jack Shaft without Sensor Mount	1	-
	1218-73	Assembly - Jack Shaft with Sensor Mount	1	-
	1218-722	Assembly - Jack Shaft without Sensor Mount	-	1
	1218-732	Assembly - Jack Shaft with Sensor Mount	-	1

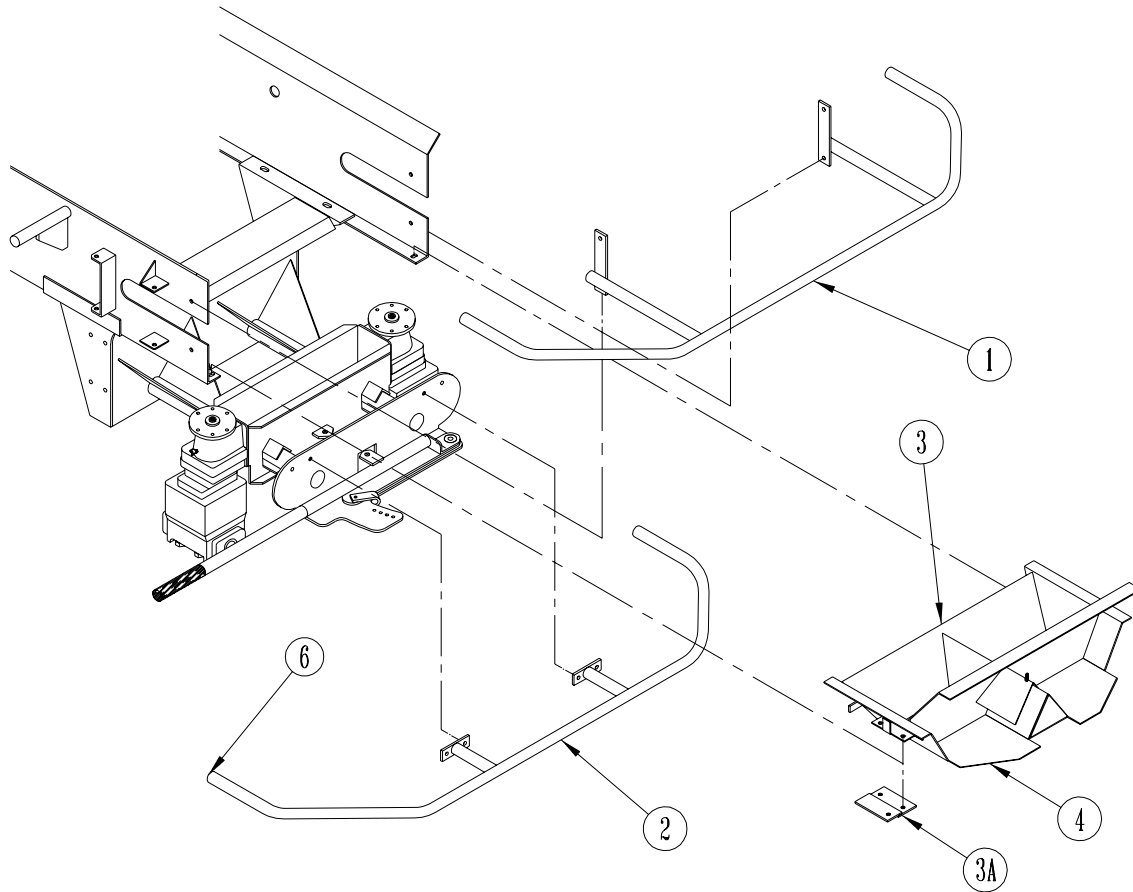

OPTIONAL SPINNER GUARDS AND MATERIAL FLOW DIVIDER

<u>ITEM</u>	<u>PART NO.</u>	<u>DESCRIPTION</u>	<u>24" ASSY QTY.</u>	<u>30" ASSY QTY.</u>
1	1236-305	Weldment - 24" Spinner Guard, Upper Requires: 1200-303SS (4) Hex Head Capscrew - 3/8" UNC X 1-1/4" SS 1209-41 (8) Flat Washer - 3/8" SS 1205-26 (4) Lock Nut - 3/8" UNC SS	1	-
1	1236-307	Weldment - 30" Spinner Guard, Upper Requires: Same as 1236-305 (Above)	-	1
2	1234-306	Weldment - 24" Spinner Guard, Lower Requires: 1200-303SS (4) Hex Head Capscrew - 3/8" UNC X 1-1/4" SS 1209-41 (8) Flat Washer - 3/8" SS 1205-26 (4) Lock Nut - 3/8" UNC SS	1	-
2	1236-308	Weldment - 30" Spinner Guard, Lower Requires: Same as 1234-306 (Above)	-	1
3	1236-402A	Weldment - 24" Material Flow Divider, Front Plate Requires: 1200-3011 (2) Hex Head Capscrew - 3/8" UNC X 1" SS 1209-41 (2) Flat Washer - 3/8" SS 1209-43 (2) Lock Washer - 3/8" SS 1205-27 (2) Nut - 3/8" UNC SS	1	-
3A	1236-404	Adapter - Mounting Requires: Same as 1234-402 (Above) Per Adapter	1-RH, 1-LH	-
3	1236-402	Weldment - 30" Material Flow Divider, Front Plate Requires: Same as 1234-402 (Above)	-	1
4	1234-403	Weldment - 24" Material Flow Divider, Back Plate Requires: 1209-41 (1) Flat Washer - 3/8" SS 1205-26 (1) Lock Nut - 3/8" SS	1	-
4	1236-403	Weldment - 30" Material Flow Divider, Back Plate Requires: Same as 1234-403 (Above)	-	1
6	1218-05	Plug - Tube, Poly	6	6

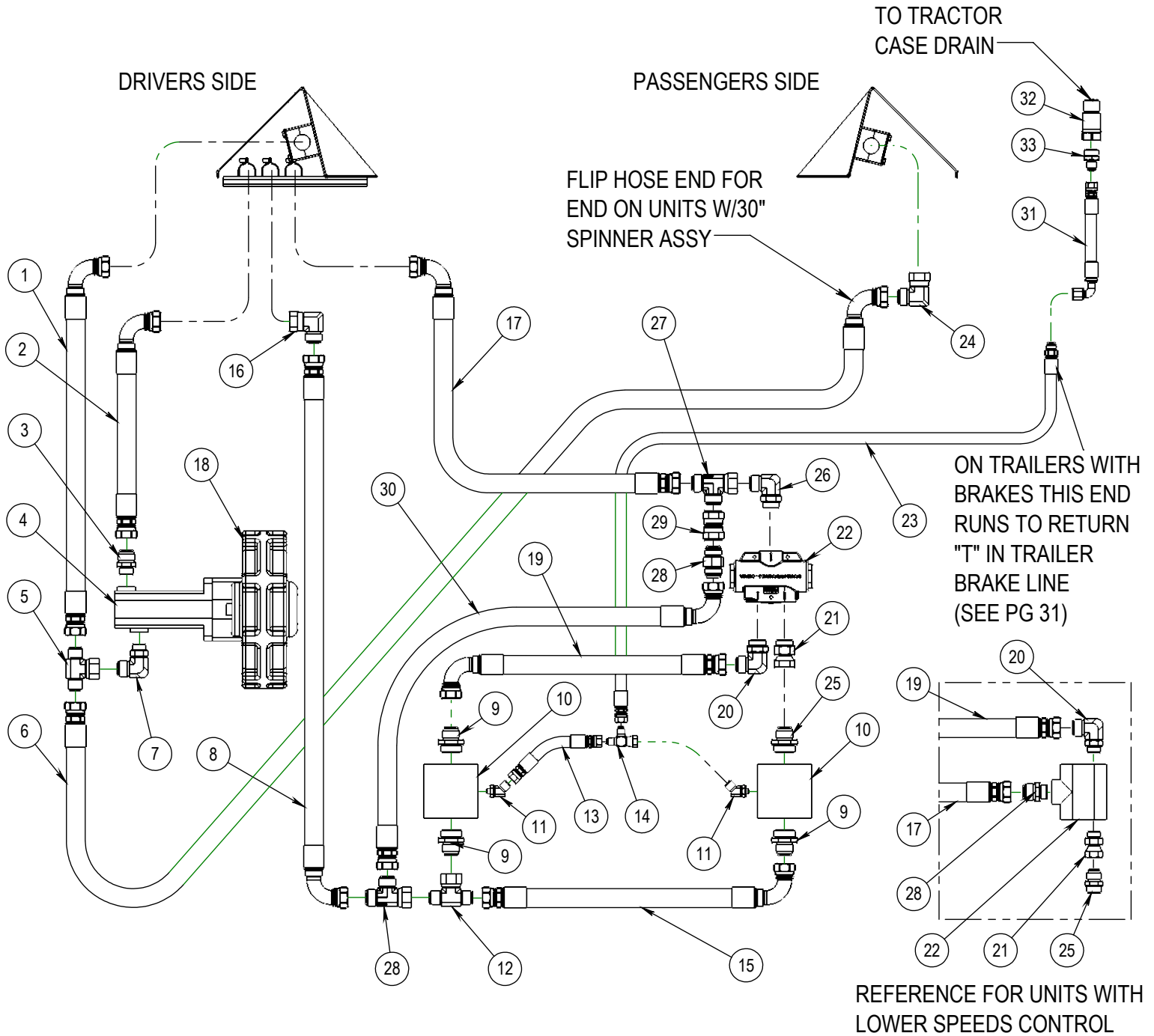

SPINNER/CONVEYOR DRIVE HYDRAULICS

FORCE UNLTD. SPREADERS*GPS EQUIPMENT*CONVEYORS

ITEM	PART NO.	DESCRIPTION	QTY
1	1207-03	Hose Ass'y	1
2	1207-04 (Agforce) 1207-041 Pro-Force	Hose Ass'y	1
3	1202-111	Adapter - Straight	1
4		Motor – Hydraulic (See Pg. 1)	
5	1202-300 (24" Spinner Assy) 1202-3015 (30" Spinner Assy.)	Adapter - Tee	1
6	1207-06 (24" Spinner Assy) 1207-065 (30" Spinner Assy)	Hose Ass'y	1
7	1202-204	Adapter - Elbow	1
8	1207-07 (24" Spinner Assy) 1207-075 (30" Spinner Assy)	Hose Ass'y	1
9	1202-112 (24" Spinner Assy) 1202-111 (30" Spinner Assy)	Adapter - Straight	3
10		Motor – Hydraulic, Spinner (See Pg. 3)	
11	1202-208	Adapter – 45 Deg	2
12	1202-300	Adapter – Tee	1
13	1207-11 (24" Spinner Assy) 1207-111 (30" Spinner Assy)	Hose	1
14	1202-3014	Adapter – Tee	1
15	1207-02 (24" Spinner Assy) 1207-021 (30" Spinner Assy)	Hose Ass'y	1
16	1202-200	Adapter – Elbow	1
17	1207-05 (24" Spinner Assy) 1207-055 (30" Spinner Assy)	Hose Ass'y	1
18		Gear Box (See Pg. 1)	
19	1207-01 (24" Spinner Assy) 1207-03 (24" Spinner Assy) 1207-011 (30" Spinner Assy)	Hose Ass'y	1
20	1202-201 (STD Spinner Speeds Control) 1202-2014 (Lower Speeds Control)	Adapter – Elbow	1
21	1202-117 (STD Spinner Speeds Control) 1202-1171 (Lower Speeds Control)	Adapter - Straight	1
22	1211-18 (STD Spinner Speeds Control) 1211-181 (Lower Speeds Control) 1211-18SP (30" Spinner Assy)	Valve _ Flow Divider	1
23	1207-721	Hose Ass'y	1
24	1202-200 (30" Spinner Assy)	Adapter – Elbow	1
25	1202-112 (24" Spinner Assy w/STD Speeds Control) 1202-1105 (24" Spinner Assy w/Lower Spinner Speeds Control) 1202-111 (30" Spinner Assy w/STD Speeds Control) 1202-110 (30" Spinner Assy w/Lower Spinner Speeds Control)	Adapter - Straight	1
26	1202-201 (STD Spinner Speeds Control) 1202-111 (Lower Spinner Speeds Control)	Adapter – Elbow Adapter - Straight	1
27	1202-3015 (30" Spinner Assy)	Adapter - Tee	2
28	1211-603 (30" Spinner Assy)	Check Valve	1
29	1202-6516 (30" Spinner Assy)	Adapter - Straight	1
30	1207-132 (30" Spinner Assy)	Hose Ass'y	1
31	1207-716	Hose Ass'y	1
32	1202-8434 1202-8433	Quick Coupler Quick Coupler Plug (w/Case Drain Opt)	1 1
33	1202-1076	Adapter – Straight	1

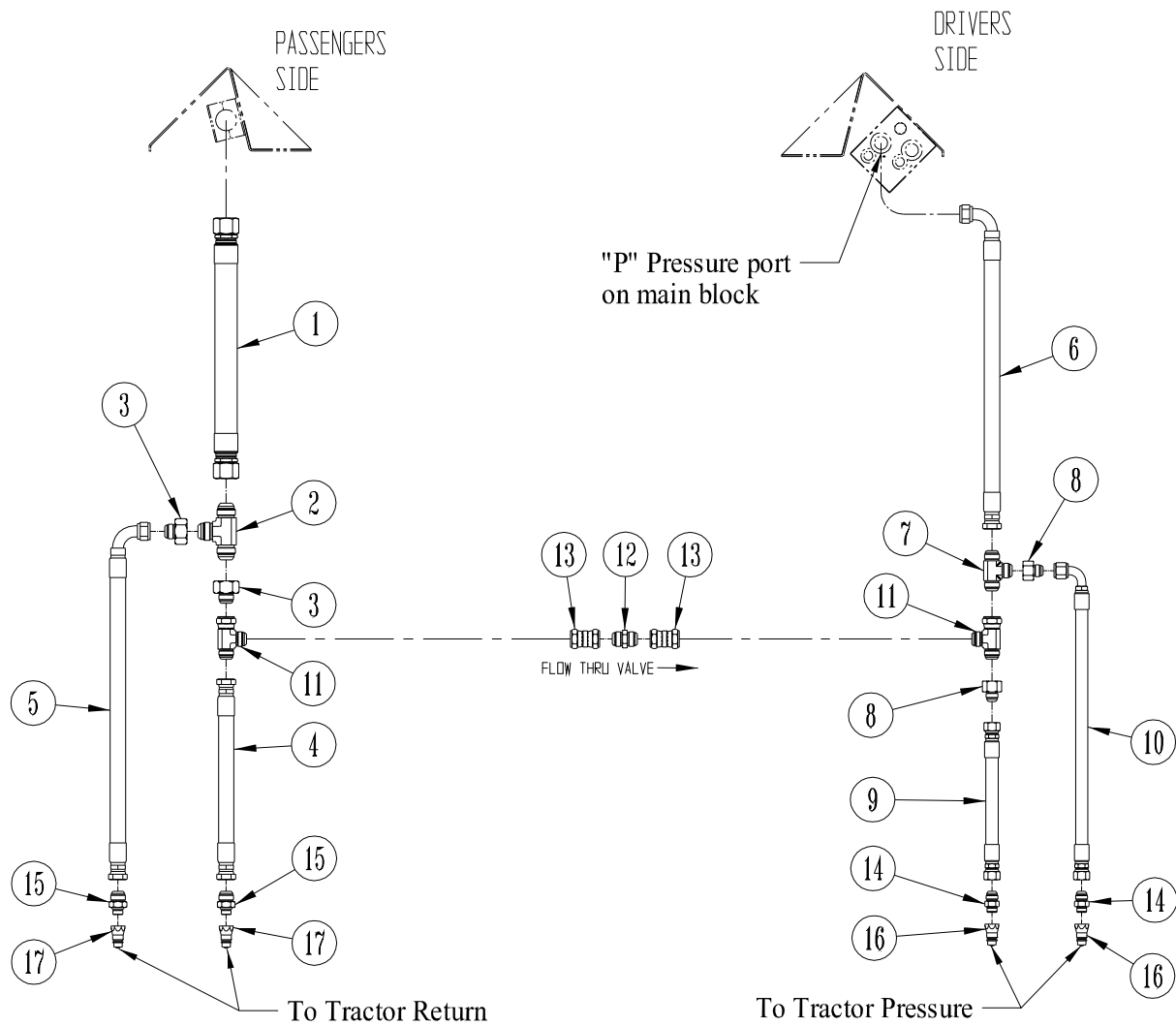

FRONT TRAILER HYDRAULICS

ITEM	PART NO.	DESCRIPTION	QTY
1	1207-732	Hose Ass'y	1
2	1202-2604	Adapter - Tee	1
3	1202-10350	Adapter - Straight	2
4	1207-731	Hose Ass'y	1
5	1207-730	Hose Ass'y	1
6	1207-733	Hose Ass'y	1
7	1202-2603	Adapter - Tee	1
8	1202-1035	Adapter - Straight	2
9	1207-735	Hose Ass'y	1
10	1207-734	Hose Ass'y	1
11	1202-3015	Adapter - Tee	2
12	1211-603	Check Valve	1
13	1202-6516	Adapter - Straight	2
14	1202-109	Adapter - Straight	2
15	1202-1100	Adapter - Straight	2
16	1202-8432	Quick Coupler	2
17	1202-8434	Quick Coupler	2

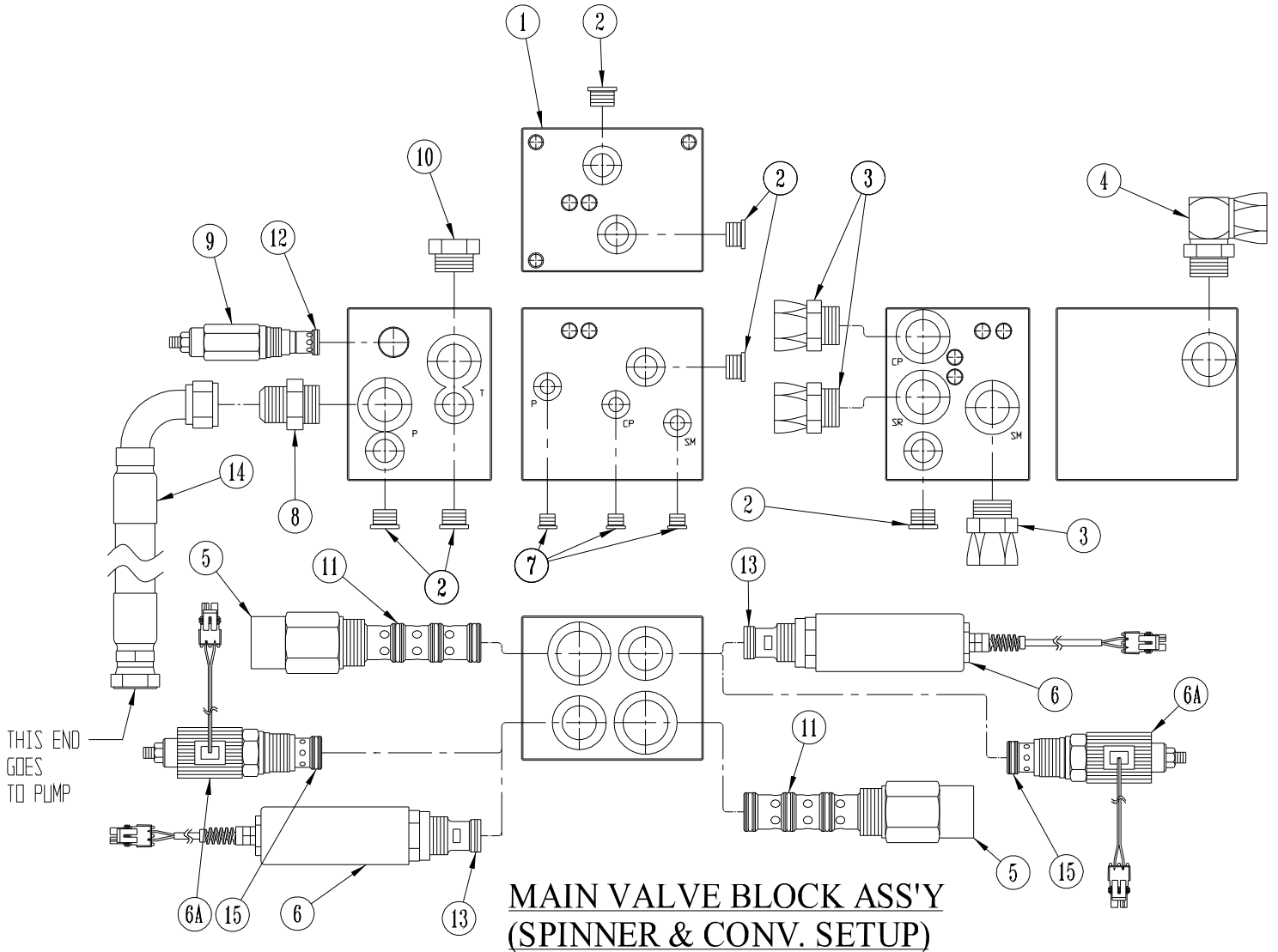

ITEM	PART NO.	DESCRIPTION	QTY
1	1211-00	Valve Block - Hydraulic Requires: 1200-400SS (3) Hex Head Capscrew - 1/2" UNC x 1" SS 1209-63 (3) Lock Washer - 1/2" SS	1
2	1202-119	Plug	6
3	1202-117	Adapter - Straight	3
4	1202-210	Adapter - Elbow	1
5	1211-80	Cartridge - PSI Compensator	2
6	1211-01 A	Valve - Hydraulic Servo	2
6A	1211-011 A	Valve - PWM	2
7	1202-118	Plug	3
8	1202-116	Adapter - Straight	1
9	1211-945	Valve - Hydraulic Relief	1
10	1202-120	Plug	1
11	1211-80K	Seal Kit	As Req'd
12	1211-95K	Seal Kit	As Req'd
13	1211-01 K	Seal Kit	As Req'd
14	1207-131	Hose Assy	1
15	1211-011SK	Seal Kit	1

Standard Main Valve Block Configuration



Note: This page is for visual purposes only.

For Details Reference: Pg. 10 Main Block (Conveyor & Spinner Setup)

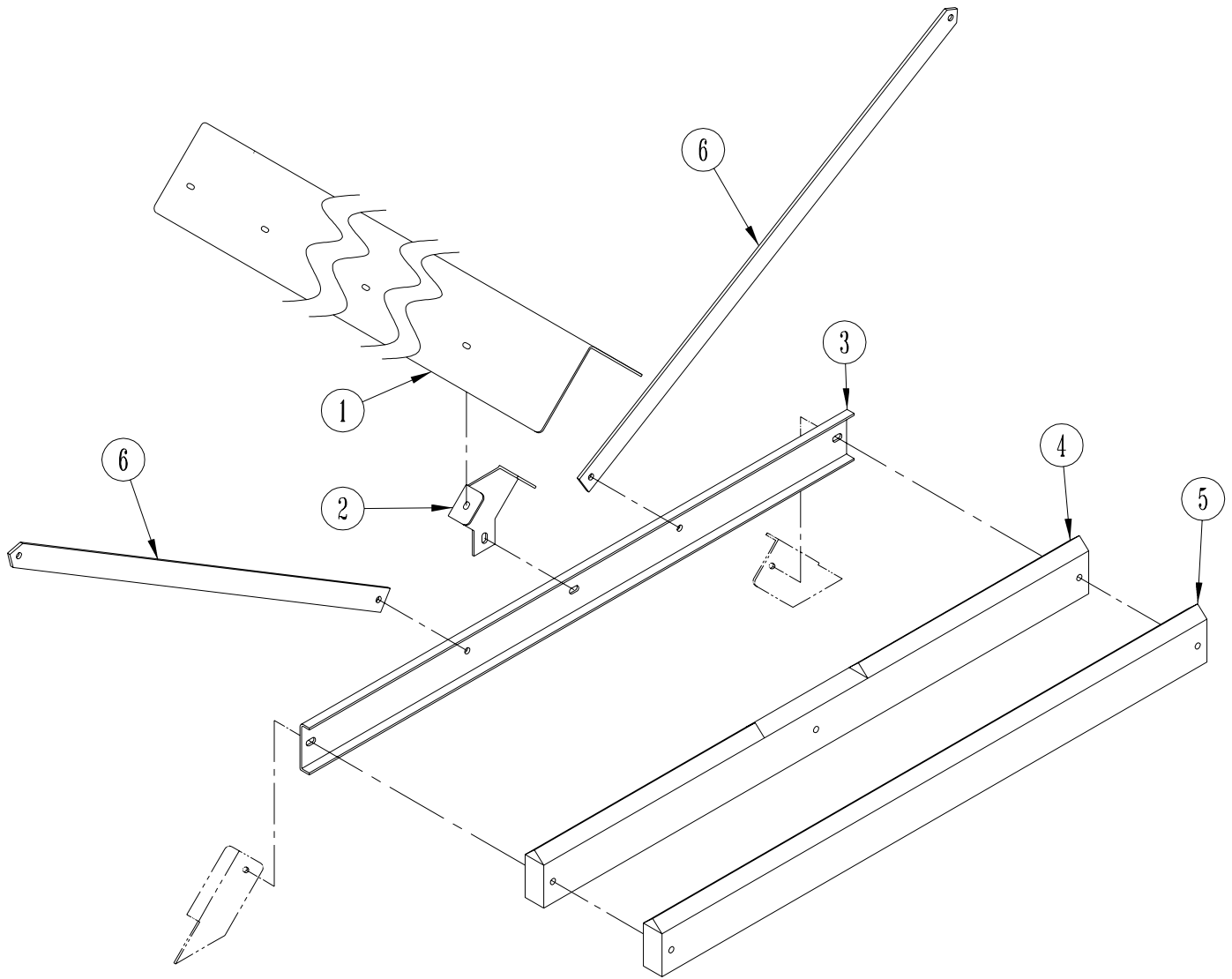

INVERTED "V" & CROSS BRACE ASSEMBLY

ITEM	PART NO.	DESCRIPTION	QTY
1	1234-105 1234-105MS 1236-1055 1236-1055MS 1200-302SS 1205-27 1209-41 1209-43	SS Inverted "V" (12'-16' Box Lengths, 102" Wide) MS Inverted "V" (12'-16' Box Lengths, 102" Wide) SS Inverted "V" (12'-18' Box Lengths, 90" Wide) (18'-28' Box Lengths, 102" Wide) MS Inverted "V" (12'-18' Box Lengths, 90" Wide) (18'-28' Box Lengths, 102" Wide) Requires: (2) Carriage Bolt - 3/8" UNC X 1" Lg. SS (2) Nut - 3/8" SS (2) Flat Washer - 3/8" SS (2) Lock Washer - 3/8" SS Per 1234-106 OR 1234-106MS (Inverted "V" Bracket)	1
2	1234-106 1234-106MS 1200-401 or 1200-412 1205-36 1209-61 1209-63	Bracket - SS Inverted "V" Bracket - MS Inverted "V" Requires: (1) Carriage Bolt - 1/2" UNC X 1 1/4" Lg. SS or Hex Head Capscrew - 1/2" UNC x 3" Lg. for use w/Asphalt style cross braces (1) Nut - 1/2" SS (1) Flat Washer - 1/2" SS (1) Lock Washer - 1/2" SS Per Bracket	2
3	1234-107 1234-107MS 1200-401 1205-36 1209-61 1209-63	Cross Brace - SS Cross Brace - MS Requires: (2) Carriage Bolt - 1/2" UNC X 1 1/4" Lg. SS (2) Nut - 1/2" SS (2) Flat Washer - 1/2" SS (2) Lock Washer - 1/2" SS Per Cross Brace	2 (12'-16' Box Lengths, 90" Wide) 3 (16'-18' Box Lengths, 90" Wide) 3 (18' Box Lengths, 102" Wide) 4 (20'-22' Box Lengths, 102" Wide) 5 (23', 24' & 26' Box Lengths, 102" Wide) 6 (28' Box Lengths, 102" Wide)
4	1236-107 1200-412 1205-36 1209-61 1209-63	Front Cross Brace Weldment - Asphalt Unit Requires: (2) Hex Head Capscrew - 1/2" UNC X 3" Lg. (2) Nut - 1/2" SS (2) Flat Washer - 1/2" SS (2) Lock Washer - 1/2" SS Per Cross Brace	2 (16'-18' Box Lengths, Asphalt Unit) 3 (21' Box Lengths, Asphalt Unit)
5	1236-107-2 1200-412 1205-36 1209-61 1209-63	Rear Cross Brace Weldment - Asphalt Unit Requires: (2) Hex Head Capscrew - 1/2" UNC X 3" Lg. (2) Nut - 1/2" SS (2) Flat Washer - 1/2" SS (2) Lock Washer - 1/2" SS Per Cross Brace	1 (Per Asphalt Unit)
6	1236-106 1236-106 MS 1236-1061 1236-1061 MS 1200-412 1200-3011 1205-36 1209-61 1209-63	Side Panel Brace for SS 102" Wide Pro-Force Side Panel Brace for MS 102" Wide Pro-Force Side Panel Brace for SS 90" Wide Pro-Force Side Panel Brace for MS 90" Wide Pro-Force Requires: (1) Hex Head Capscrew - 3/8" UNC X 3" Lg. (1) Hex Head Capscrew - 3/8" UNC X 1" Lg. SS (2) Nut - 3/8" SS (2) Flat Washer - 3/8" SS (2) Lock Washer - 3/8" SS Per Brace	2 Per 16' & 17' Pro-Force 4 Per 18' - 26' Pro-Force 6 Per 28' Pro-Force

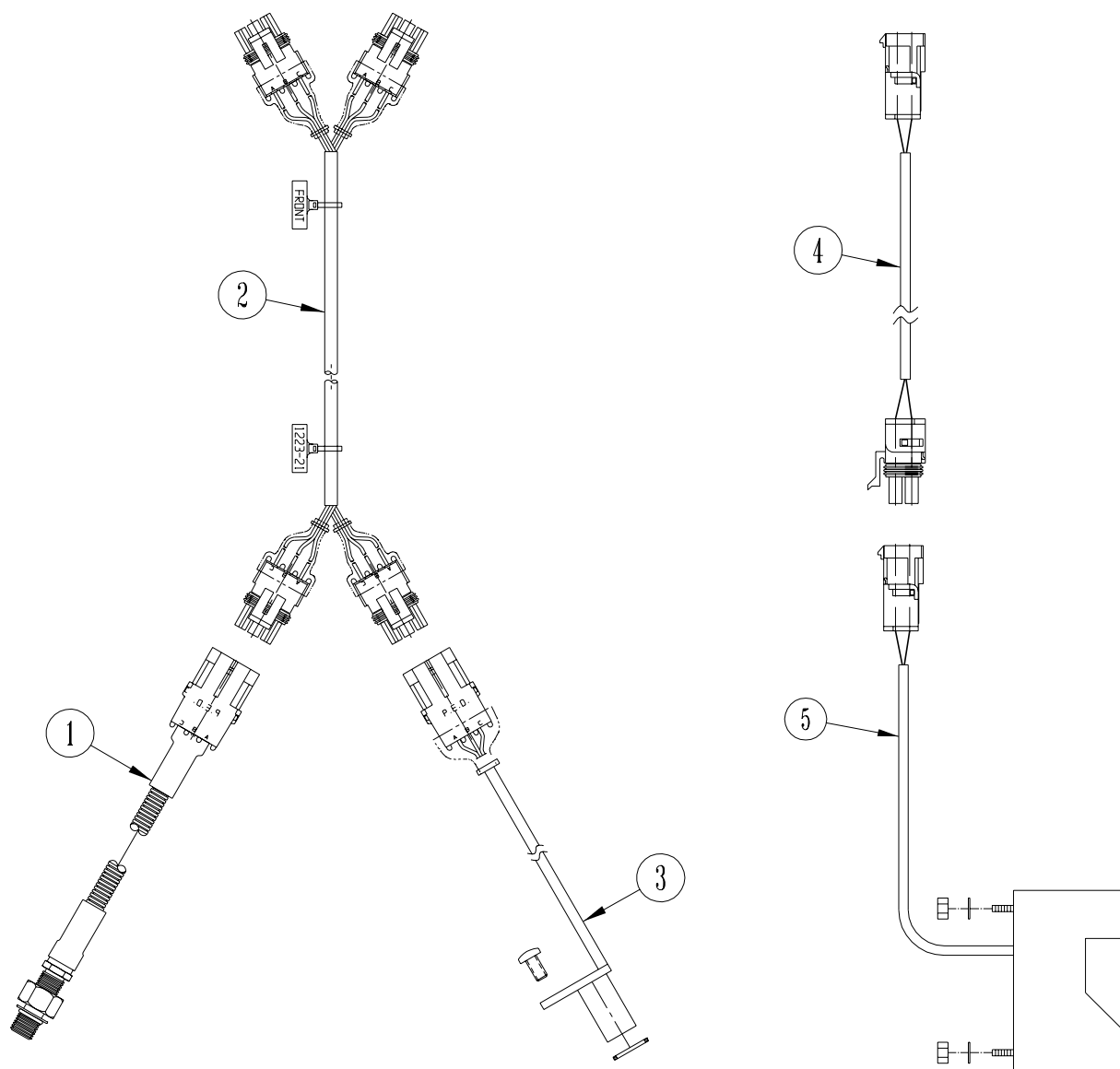

SENSOR WIRING HARNESS

<u>ITEM</u>	<u>PART NO.</u>	<u>DESCRIPTION</u>	<u>QTY</u>
1	1223-600	Sensor - Conveyor Speed	1
2	1223-21	Cable Assy - Sensor	1
3	1223-22	Sensor - Hub Assy	1
4	1223-829	Optional Cable - Ass'y Bin Level	1
5	1223-64	Optional Sensor - Bin Level	1

FORCE UNLTD.

SPREADERS*GPS EQUIPMENT*CONVEYORS

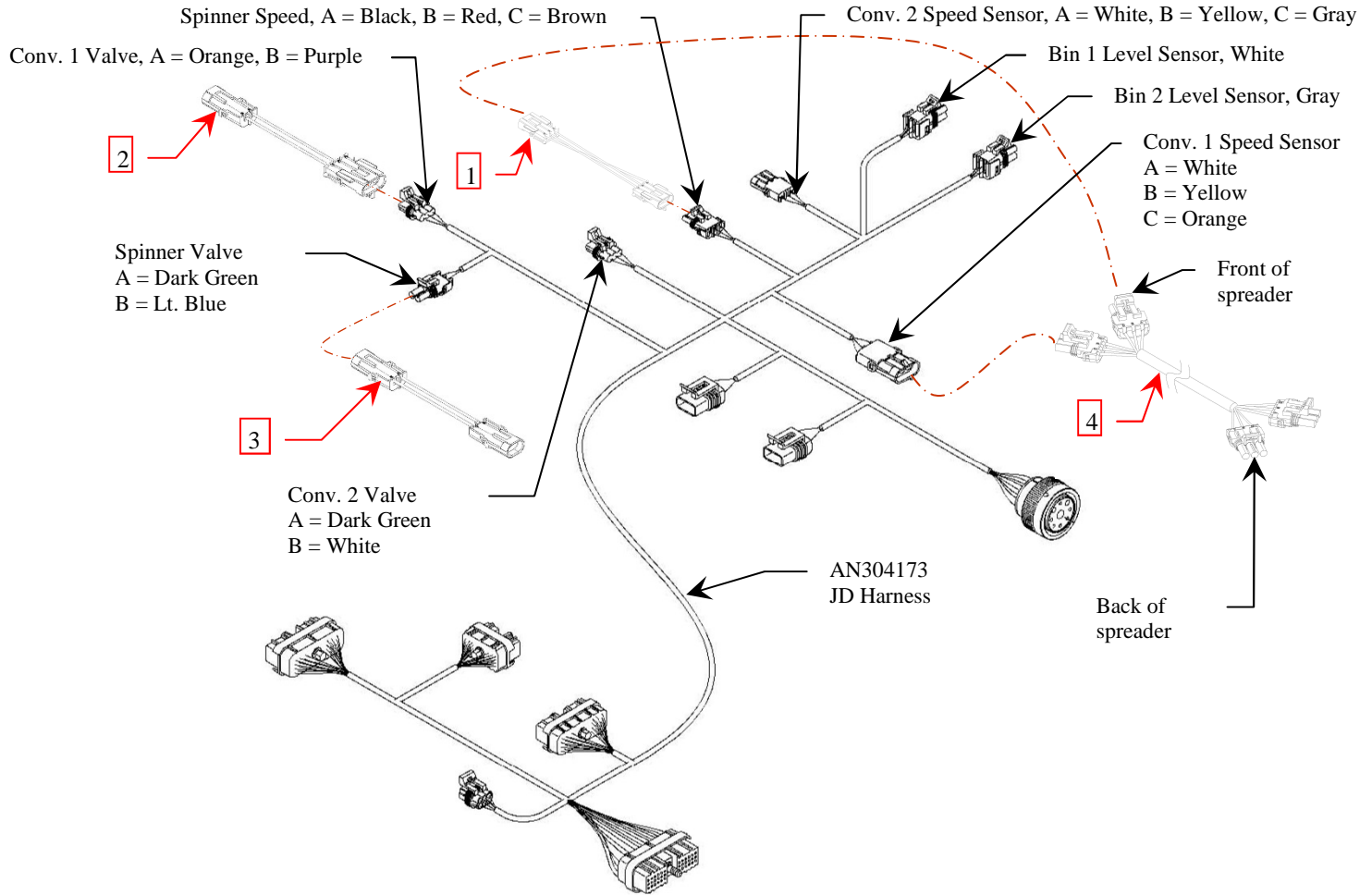

John Deere AN304173 Electrical Harness Adapter Kit

<u>ITEM</u>	<u>PART NO.</u>	<u>DESCRIPTION</u>	<u>QTY.</u>
1	1223-403	Adapter Cable - Spinner Speed Sensor	1
2	1223-402	Adapter Cable - Conveyor 1 Servo Valve	1
3	1223-4040	Adapter Cable - Spinner Valve	1
4	1223-21	Cable Assy - Sensor	1

John Deere Parts Required for Trailer Units

<u>JD PART NO.</u>	<u>DESCRIPTION</u>	<u>QTY.</u>
PF81045	Foot Switch Kit	1
AN304988	Wiring Harness - Implement Switch to Foot Switch	1
AN304156	Wiring Harness - Tractor to Spreader	1
AN207114	Control	1
AN304173	Wiring Harness (Shown in diagram above)	1

Part #'s listed are current as of Jan. 2010 - Verify with your local JD Dealer.

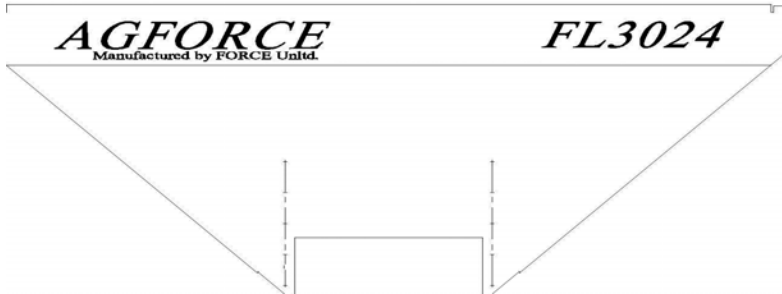

Decals

<u>ITEM</u>	<u>PART NO.</u>	<u>DESCRIPTION</u>	<u>QTY.</u>
1	1234-060 1234-061 1234-062	Decal - AGFORCE (Red) Decal - AGFORCE (Black) Decal - AGFORCE (Black/Yellow)	3
2	1234-040 1234-041 1234-042	Decal - FL3024 (Red) Decal - FL3024 (Black) Decal - FL3024 (Black/Yellow)	3
3	1234-055	Decal - Chain Tension	1
4	1234-056	Decal - Hydraulic Oil	1

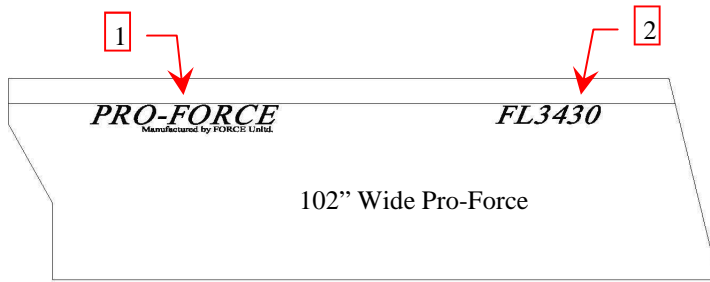

Front

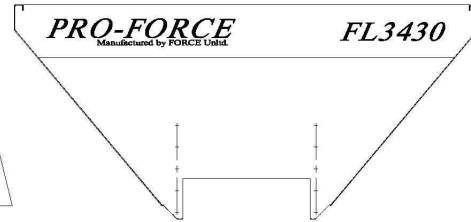

Rear

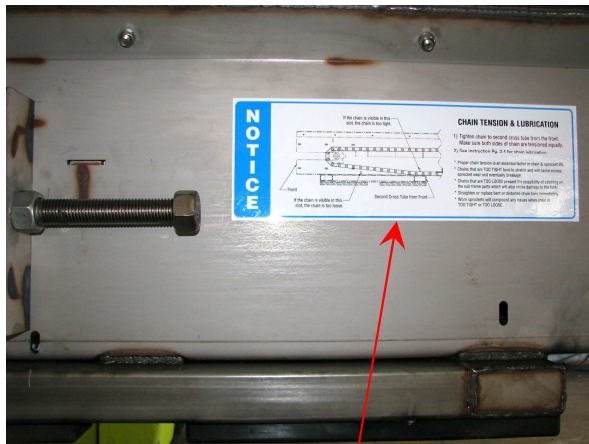
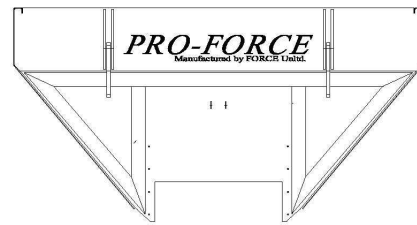
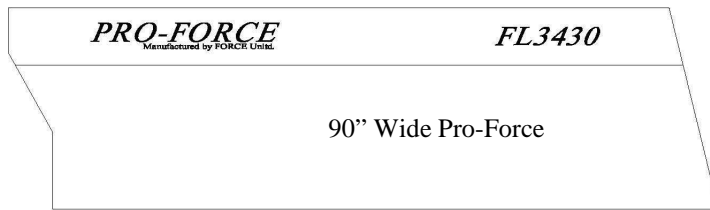

3



4

Decals

<u>ITEM</u>	<u>PART NO.</u>	<u>DESCRIPTION</u>	<u>SWINGING ENDGATE QTY'S</u>	<u>SOLID REAR PANEL QTY'S</u>
1	1236-060	Decal, PRO-FORCE (Red)	3	3
	1236-060 B	Decal, PRO-FORCE (Black)	3	3
	1236-060W	Decal, PRO-FORCE (White)	3	3
2	1236-041	Decal - FL3430 (Red)	2	3
	1236-041 B	Decal - FL3430 (Black)	2	3
	1236-041 W	Decal - FL3430 (White)	2	3
3	1234-055	Decal - Chain Tension	1	1
4	1234-056	Decal - Hydraulic Oil	1	1

GEAR BOX

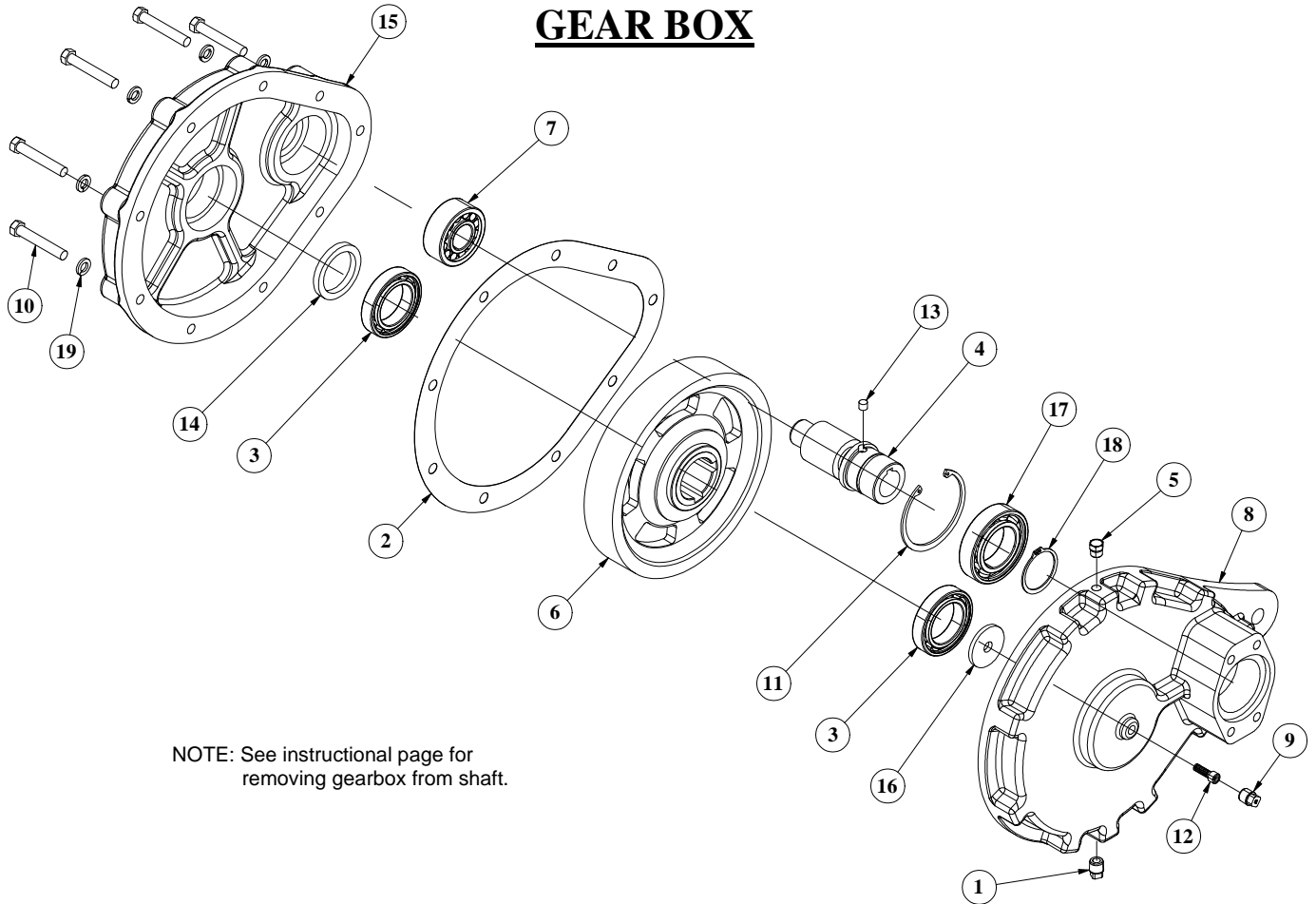

NOTE: See instructional page for removing gearbox from shaft.

ITEM	PART NO.	DESCRIPTION	QTY
1	1201-238M	Plug - 1/2" Square Head, Magnetic	1
2	1204-08	Gasket	1
3	1217-104	Bearing	2
4	1217-110	Gear - Pinion	1
5	1220-501	Breather	1
6	1217-111	Gear - Driven	1
7	1217-105	Bearing - Small - Pinion Nose	1
8	1220-50-O	Housing - Outboard, Gearbox	1
9	1201-238	Plug - 1/2" Square Head	1
10	1200-327	Hex Head Capscrew - 7/16" UNC x 2 3/4"	9
11	1208-97	Snap Ring	1
12	1200-251A	Capscrew - Socket Head 5/16-18 x 1"	1
13	1217-110P	Plug - Delrin	1
14	1204-07	Seal	1
15	1220-50-I	Housing - Inboard, Gearbox	1
16	1209-100	Washer - Retainer	1
17	1217-106	Bearing - Large - Pinion Shaft	1
18	1208-06	Snap Ring	1
19	1209-102	Lock Washer - 7/16"	9

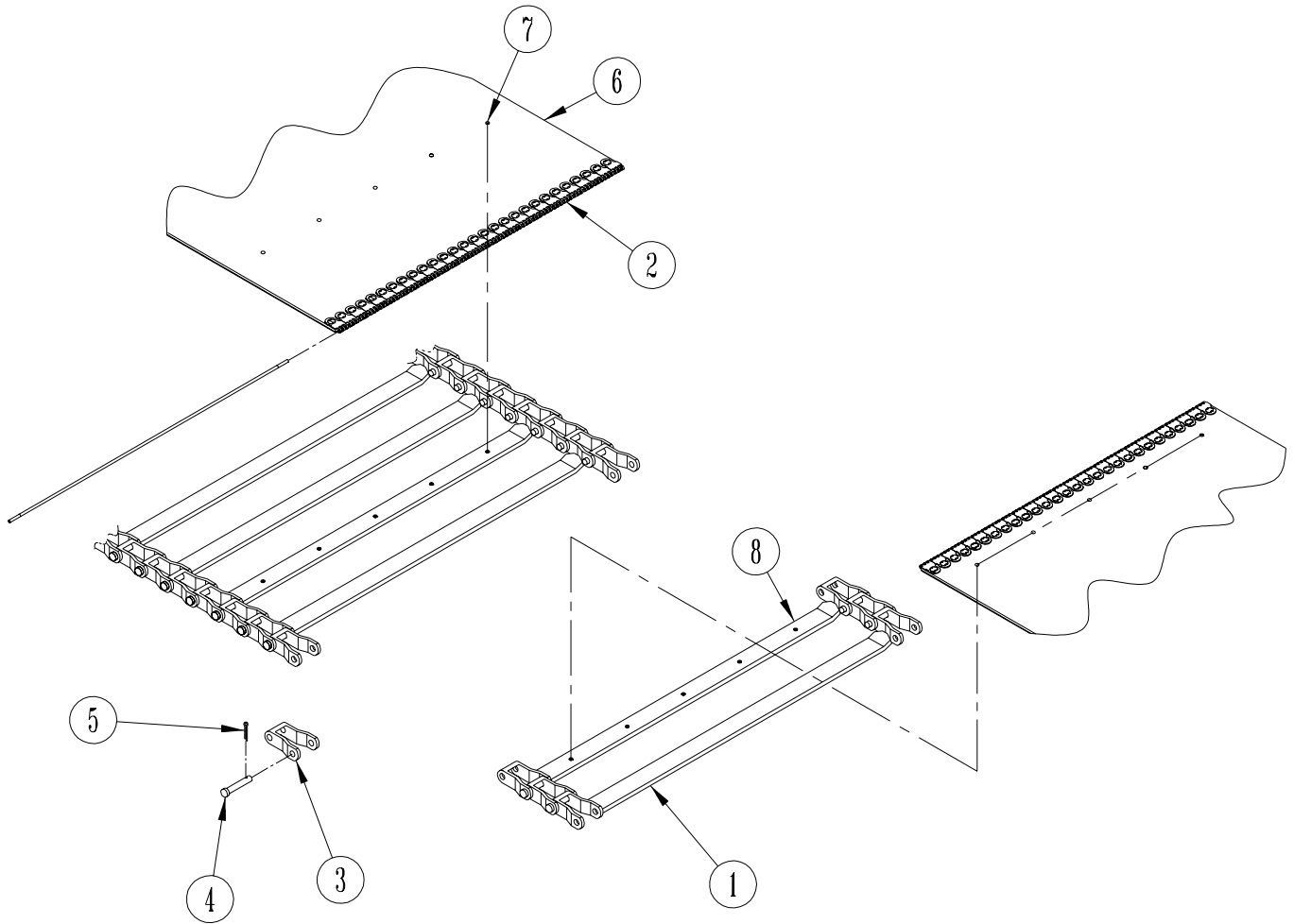

BELT OVER PINTLE CHAIN

<u>ITEM</u>	<u>PART NO.</u>	<u>DESCRIPTION</u>	<u>QTY.</u>
1	1 236-907	Weldment - Crossbar (without holes)	As Req'd
2	1 000-42 1 000-43	Splice Kit - M/S Splice Kit - S/S	1
3	1 234-901	Link - Pintle Chain	As Req'd
4	1 234-902	Pin - Pintle Chain	As Req'd
5	1 234-903	Cotter Pin	As Req'd
6	1 000-29 1 000-29TK	Belt - Conveyor (Specify Box Length) High Temp. Belt - Conveyor (Specify Box Length)	As Req'd As Req'd
7	1 209-40C 1 209-41C 1 200-248 1 200-249 1 200-251 5	Washer - Dimpled M/S Washer - Dimpled S/S Allen Head Cap Screw - Alloy Steel Allen Head Cap Screw - Stainless Steel Allen Head Cap Screw - Alloy Steel (Used on High Temp BOC only)	As Req'd
8	1 236-908	Weldment - Crossbar (with holes)	As Req'd

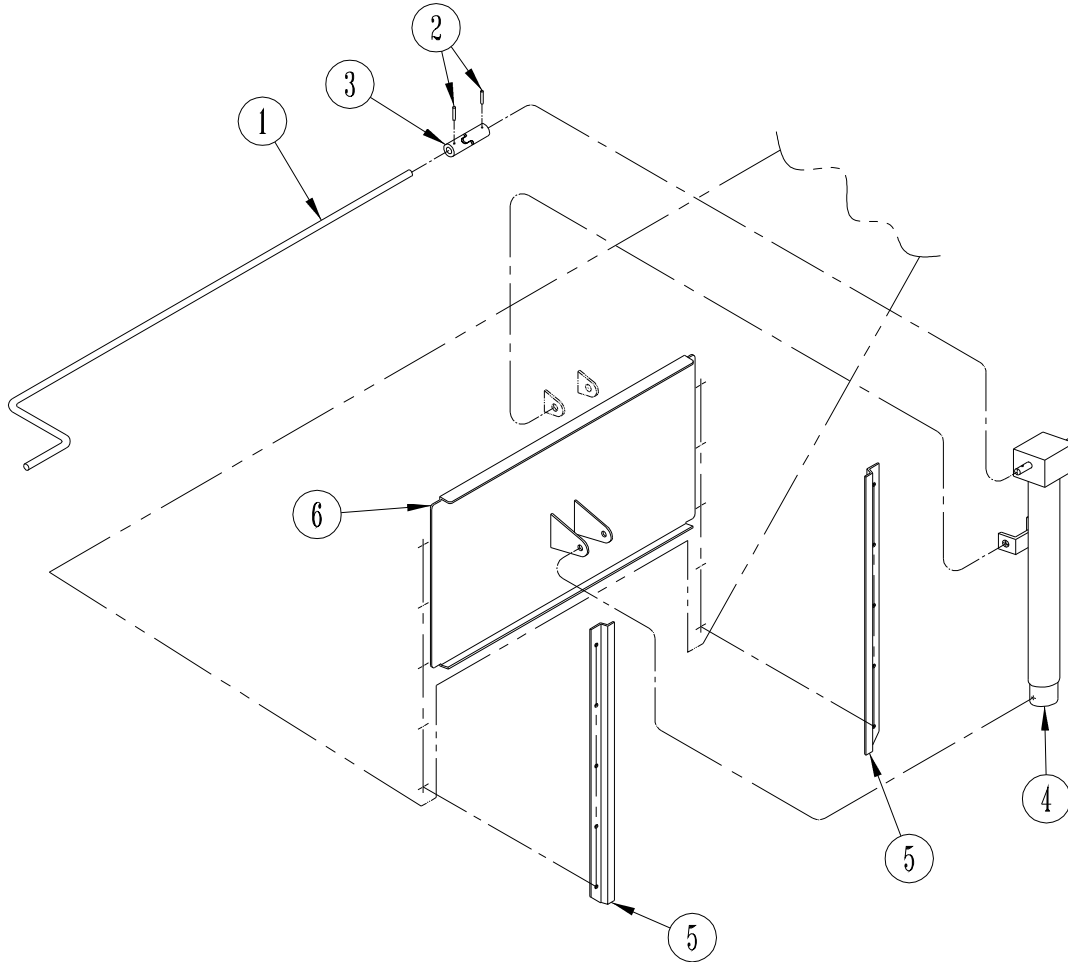

FEEDGATE ASSEMBLY w/SOLID REAR PANEL

ITEM	PART NO.	DESCRIPTION	QTY
1	1218-81 1218-81SS	Handle- MS Handle- SS	1
2	1208-015	Roll Pin	2
3	1218-85	U-Joint	1
4	1218-80 1200-310 1209-42 1205-21 1200-416 1209-62 1205-37	Assembly - Jack Lower Tab Requires: (1) Hex Head Capscrew - 3/8" UNC x 3" MS (1) Lock Washer - 3/8" MS (1) Nut - 3/8" UNC MS Upper Tab Requires: (1) Hex Head Capscrew - 1/2" UNC x 4" MS (1) Lock Washer - 1/2" MS (1) Nut - 1/2" UNC MS	1
5	1218-86	SS Slides - Feedgate	1-RH, 1-LH
5	1218-86MS 1200-202 1209-22 1205-11	MS Slides - Feedgate Requires (Per Slide): (5) Hex Head Capscrew - 1/4" UNC x 1" SS (5) Lock Washer - 1/4" SS (5) Nut - 1/4" UNC SS	1-RH, 1-LH
6	1236-350	Weldment - SS Feedgate	1
6	1236-350MS	Weldment - MS Feedgate	1

SWINGING ENDGATE & FEEDGATE ASSEMBLY

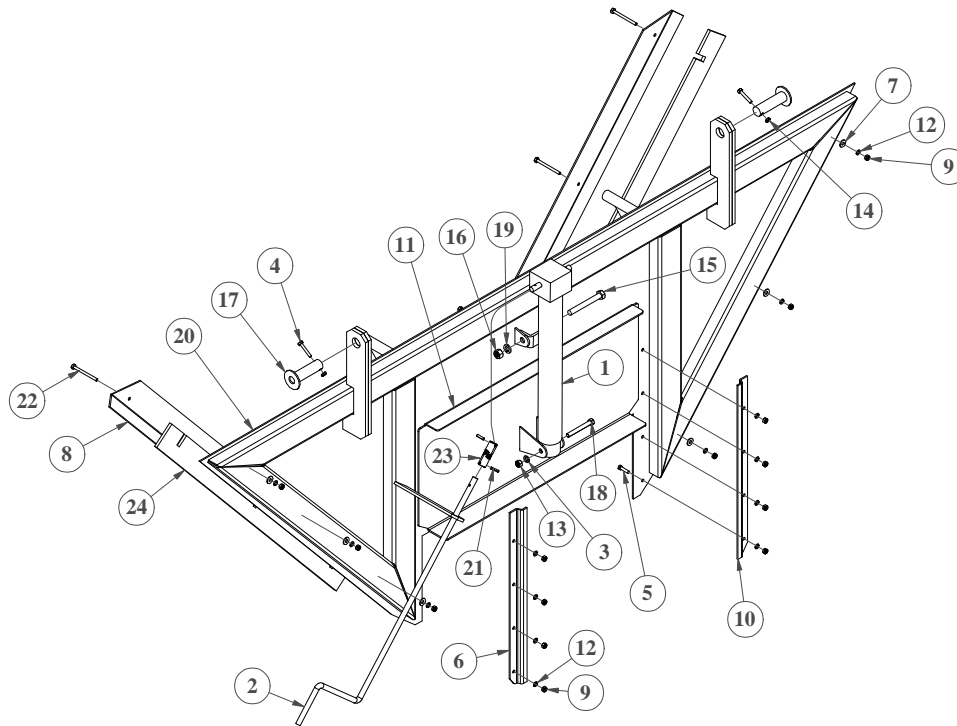

ITEM	PART NO.	DESCRIPTION	QTY
1	1218-80	Assembly - Jack	1
2	1218-81S	Handle (Specify material)	1
3	1209-42	Lock Washer - 3/8"	1
4	1200-2049	Hex Head Cap Screw - 1/4" UNC x 1 1/2" SS	2
5	1200-202	Hex Head Capscrew - 1/4" UNC x 1" Lg. SS	8
6	1218-86S LH	Feedgate Slide - LH (Specify material)	1
7	1209-25S	Flat Washer - 1/4" SS	6
8	1236-652	Swinging Endgate Seal Strip Pinch Plate (Specify material)	2
9	1205-11	Nut - 1/4" UNC SS	14
10	1218-86S RH	Feedgate Slide - RH (Specify material)	1
11	1236-350S	Weldment - Feedgate (Specify material & if it is reinforced)	1
12	1209-22	Lock Washer - 1/4" SS	14
13	1205-21	Nut - 3/8" UNC	1
14	1205-501	Lock Nut - 1/4" UNC SS	2
15	1200-416	Hex Head Capscrew - 1/2" UNC x 4"	1
16	1205-37	Nut - 1/2" UNC	1
17	1236-651	Weldment - Pin, (Specify material)	2
18	1200-310	Hex Head Capscrew - 3/8" UNC x 3" MS	1
19	1209-62	Lock Washer - 1/2"	1
20	1236-650	Weldment - Swinging Endgate (Specify material)	1
21	1208-015	Roll Pin	2
22	1200-212	Hex Head Cap Screw - 1/4" UNC x 3" SS	6
23	1218-85	U-Joint	1
24	1236-653	Swinging Endgate Seal Strip (Specify standard or high temp)	2

SWINGING ENDGATE CATCH/RELEASE ASSEMBLY

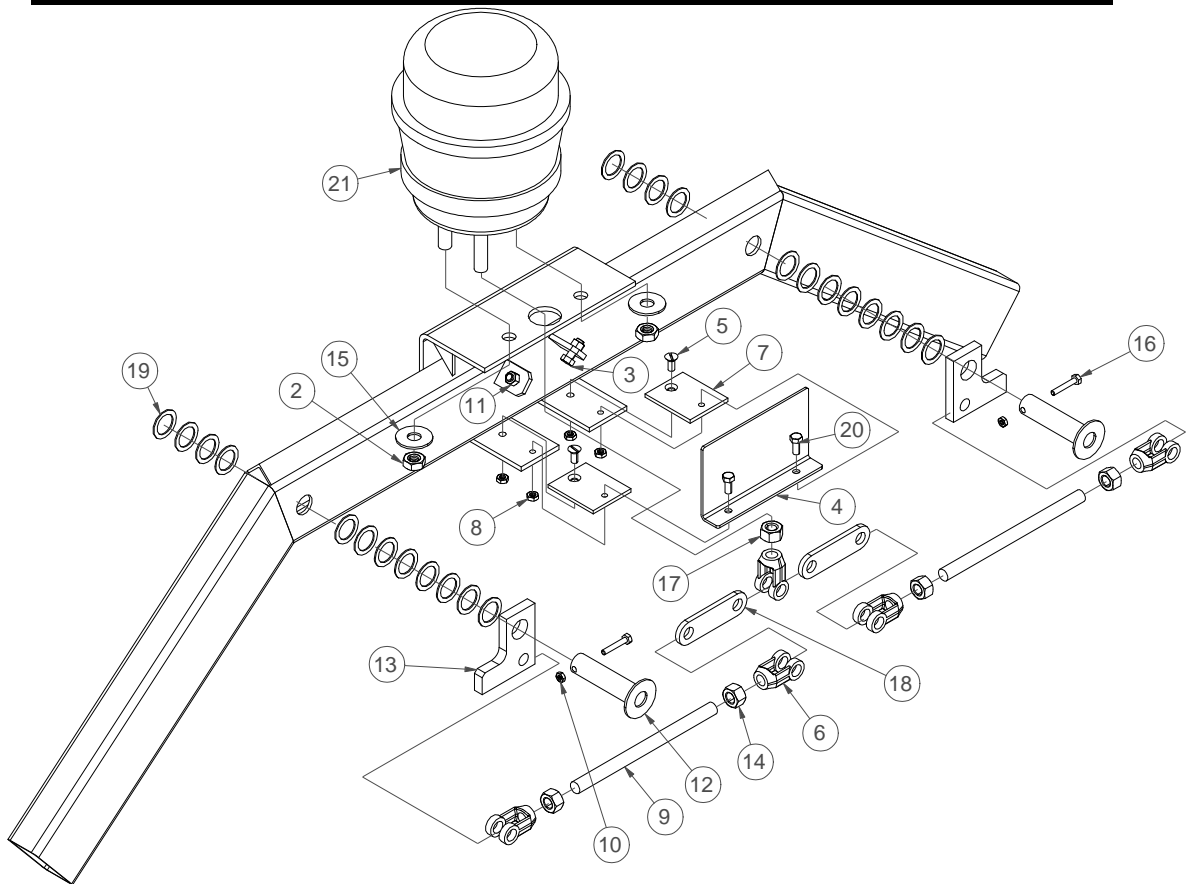

ITEM	PART NO.	DESCRIPTION	QTY
2	1205-47	Lock Nut - 5/8" UNC	2
3	1200-301	Hex Head Cap Screw - 3/8" UNC x 1"	2
4	1236-354	Linkage Guide Plate	1
5	1200-248	Flat Head Cap Screw - 5/16" UNC x 3/4"	2
6	1208-04	Yoke Kit	5
7	1236-351	Linkage Slide Surface	2
8	1205-17	Lock Nut - 5/16" UNC	4
9	1225-05	Adjusting Rod	2
10	1205-10	Lock Nut - 1/4" UNC	2
11	1205-21	Nut - 3/8" UNC	2
12	1208-025	Pin	2
13	1236-353	Door Catch	2
14	1205-52	Nut - 5/8" UNF	4
15	1209-70	Flat Washer - 5/8" MS	2
16	1200-205	Hex Head Cap Screw - 1/4" UNC x 1 1/2"	2
17	1205-51	Nut - 5/8" UNC MS	1
18	1236-352	Linkage	2
19	1209-96	Machinery Washer - 1"	24
20	1200-250	Hex Head Cap Screw - 5/16" UNC x 3/4"	2
21	1222-02	Air Brake Actuator	1

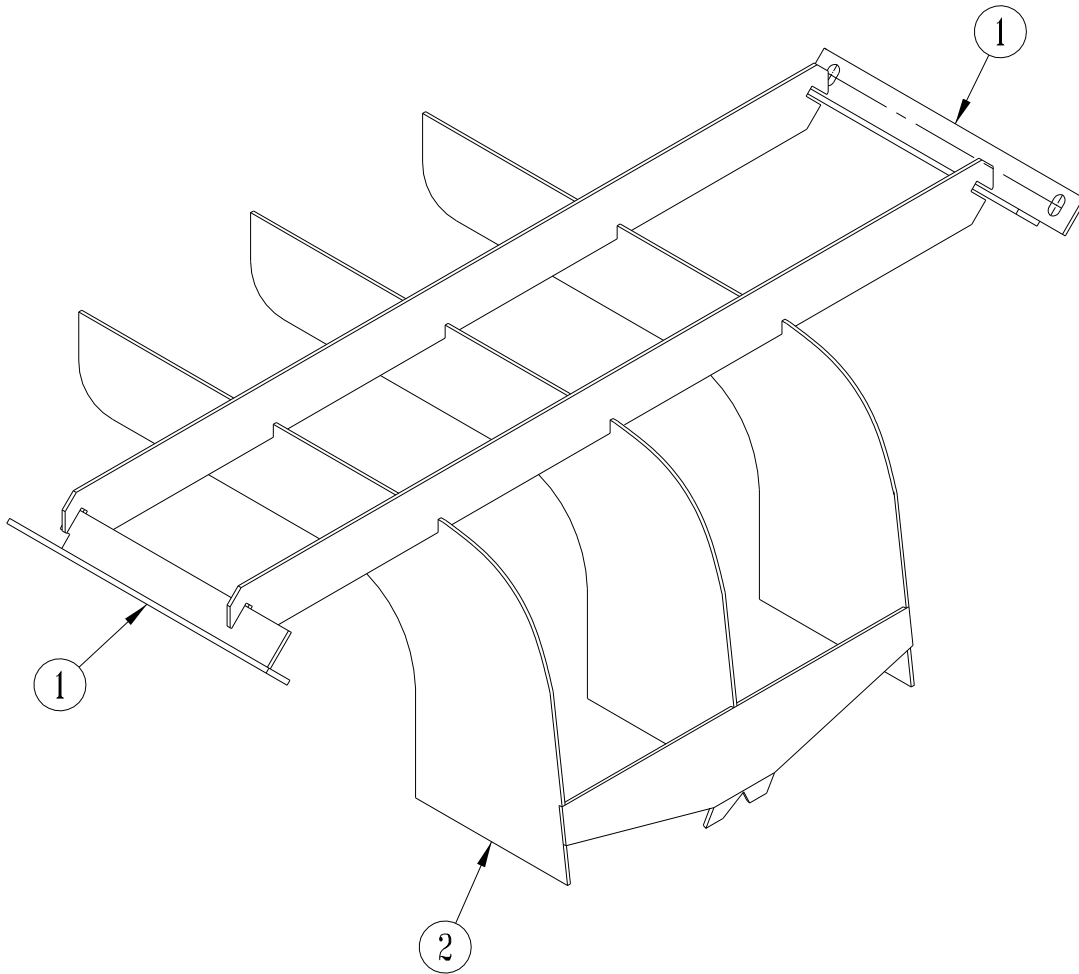

OPTIONAL HILLSIDE FLOW DIVIDER

<u>ITEM</u>	<u>PART NO.</u>	<u>DESCRIPTION</u>	<u>QTY.</u>
	1236-451	Assembly - Hillside Flow Divider	
1	1234-452	Bracket - Mounting Requires: 1200-302SS (2) Carriage Bolt - 3/8" UNC x 1" S/S 1209-41 (2) Flat Washer - 3/8" S/S 1209-43 (2) Lock Washer - 3/8" S/S 1205-27 (2) Nut - 3/8" UNC S/S Per Bracket	1 -RH, 1 -LH
2	1236-453	Weldment - Hillside Flow Divider	1

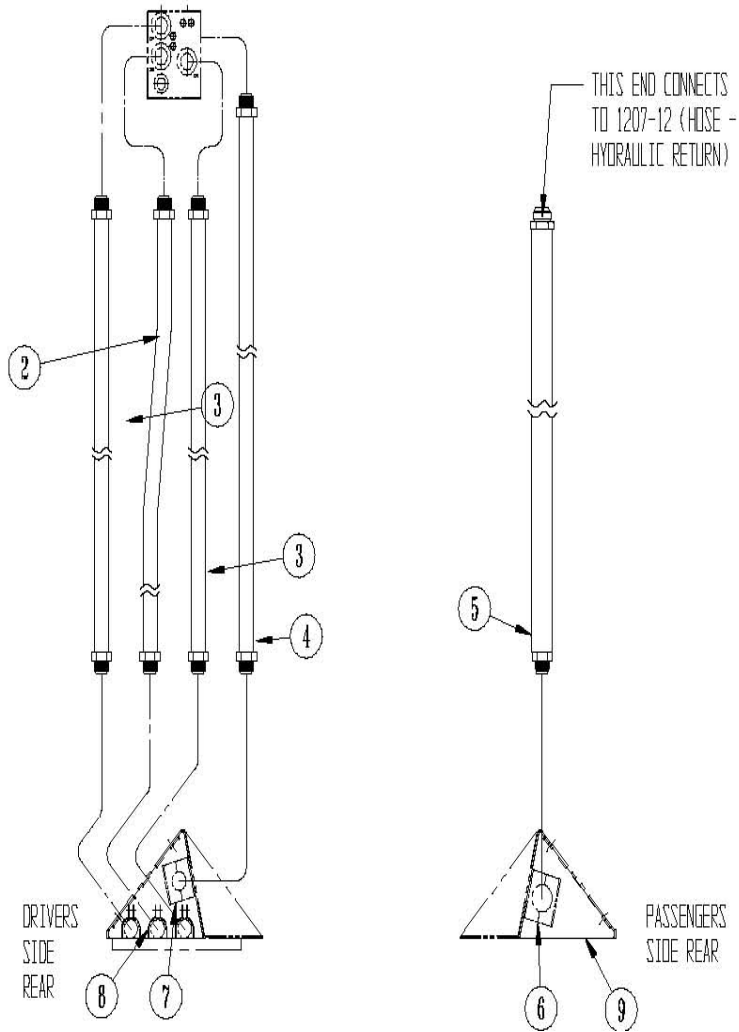

HYDRAULIC PIPES

FORCE UNLTD. SPREADER * CONVEYORS

ITEM	PART NO.	DESCRIPTION	QTY.
2	1234-532 1234-533 1234-534 1234-535 1236-536 1236-537 1236-538 1236-539 1236-530 1236-531 1236-532 1236-533 1236-534 1236-5346	Hydraulic Pipe -12' Box Hydraulic Pipe -13' Box Hydraulic Pipe -14' Box Hydraulic Pipe -15' Box Hydraulic Pipe -16' Box Hydraulic Pipe -17' Box Hydraulic Pipe -18' Box Hydraulic Pipe -19' Box Hydraulic Pipe -20' Box Hydraulic Pipe -21' Box Hydraulic Pipe -22' Box Hydraulic Pipe -23' Box Hydraulic Pipe -24' Box Hydraulic Pipe -26' Box	1
3	1234-522 1234-523 1234-524 1234-525 1236-526 1236-527 1236-528 1236-529 1236-520 1236-521 1236-522 1236-523 1236-524 1236-5246	Hydraulic Pipe -12' Box Hydraulic Pipe -13' Box Hydraulic Pipe -14' Box Hydraulic Pipe -15' Box Hydraulic Pipe -16' Box Hydraulic Pipe -17' Box Hydraulic Pipe -18' Box Hydraulic Pipe -19' Box Hydraulic Pipe -20' Box Hydraulic Pipe -21' Box Hydraulic Pipe -22' Box Hydraulic Pipe -23' Box Hydraulic Pipe -24' Box Hydraulic Pipe -26' Box	2
4	1234-552 1234-553 1234-554 1234-555 1236-556 1236-557 1236-558 1236-559 1236-550 1236-551 1236-552 1236-553 1236-554 1236-5546	Hydraulic Pipe -12' Box Hydraulic Pipe -13' Box Hydraulic Pipe -14' Box Hydraulic Pipe -15' Box Hydraulic Pipe -16' Box Hydraulic Pipe -17' Box Hydraulic Pipe -18' Box Hydraulic Pipe -19' Box Hydraulic Pipe -20' Box Hydraulic Pipe -21' Box Hydraulic Pipe -22' Box Hydraulic Pipe -23' Box Hydraulic Pipe -24' Box Hydraulic Pipe -26' Box	1
5	1234-542 1234-543 1234-544 1234-545 1236-546 1236-547 1236-548 1236-549 1236-540 1236-541 1236-542 1236-543 1236-544 1236-5446	Hydraulic Pipe -12' Box Hydraulic Pipe -13' Box Hydraulic Pipe -14' Box Hydraulic Pipe -15' Box Hydraulic Pipe -16' Box Hydraulic Pipe -17' Box Hydraulic Pipe -18' Box Hydraulic Pipe -19' Box Hydraulic Pipe -20' Box Hydraulic Pipe -21' Box Hydraulic Pipe -22' Box Hydraulic Pipe -23' Box Hydraulic Pipe -24' Box Hydraulic Pipe -26' Box	1
6	1208-93	Clamp - Pipe	2 (12'-14' Boxes) 3 (16'-26' Boxes)
7	1208-92	Clamp Pipe	1 (12'-14' Boxes) 2 (16'-26' Boxes)
8	1208-96	Clamp - Pipe	3
9	1234-559 1200-3011 1205-27 1209-43	Cap-Hydraulic Line Cover Requires: (2) Hexhead Capscrew - 3/8"UNC 1"SS (2) Hex Nut - 3/8" UNC SS (2) Lock Washer - 3/8" SS Per Cover	1-RH, 1-LH

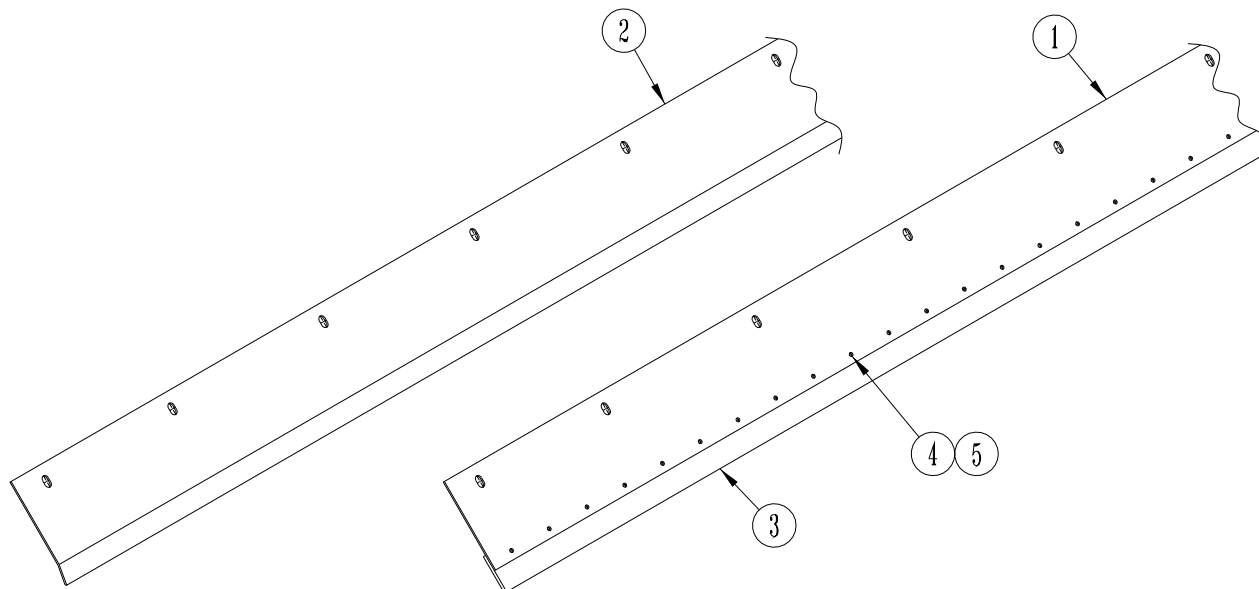

CHAIN SHIELDS

ITEM	MS PART NO.	SS PART NO.	DESCRIPTION	QTY	
1	1234-912MS	1234-912	Weldment - Chain Shield #4 BOC - 12' Box	1-RH, 1-LH	
	1234-913MS	1234-913	Weldment - Chain Shield #4 BOC - 13' Box		
	1234-914MS	1234-914	Weldment - Chain Shield #4 BOC - 14' Box		
	1236-916MS	1236-916	Weldment - Chain Shield #4 BOC - 16' Box		
	1236-917MS	1236-917	Weldment - Chain Shield #4 BOC - 17' Box		
	1236-918MS	1236-918	Weldment - Chain Shield #4 BOC - 18' Box		
	1236-920MS	1236-920	Weldment - Chain Shield #4 BOC - 20' Box		
	1236-921MS	1236-921	Weldment - Chain Shield #4 BOC - 21' Box		
	1236-922MS	1236-922	Weldment - Chain Shield #4 BOC - 22' Box		
	1236-923MS	1236-923	Weldment - Chain Shield #4 BOC - 23' Box		
	1236-924MS	1236-924	Weldment - Chain Shield #4 BOC - 24' Box		
	1236-926MS	1236-926	Weldment - Chain Shield #4 BOC - 26' Box		
			Requires:		
			1200-302SS Carriage Bolt - 3/8" UNC x 1" SS		As Req'd
			1209-43 Lock Washer - 3/8" SS		
		1205-27 Nut - 3/8" UNC SS			
2	1234-932MS	1234-932	Weldment - Chain Shield #2 Chain only - 12' Box	1-RH, 1-LH	
	1234-933MS	1234-933	Weldment - Chain Shield #2 Chain only - 13' Box		
	1234-934MS	1234-934	Weldment - Chain Shield #2 Chain only - 14' Box		
	1236-936MS	1236-936	Weldment - Chain Shield #2 Chain only - 16' Box		
	1236-937MS	1236-937	Weldment - Chain Shield #2 Chain only - 17' Box		
	1236-938MS	1236-938	Weldment - Chain Shield #2 Chain only - 18' Box		
	1236-940MS	1236-940	Weldment - Chain Shield #2 Chain only - 20' Box		
	1236-941MS	1236-941	Weldment - Chain Shield #2 Chain only - 21' Box		
	1236-942MS	1236-942	Weldment - Chain Shield #2 Chain only - 22' Box		
	1236-943MS	1236-943	Weldment - Chain Shield #2 Chain only - 23' Box		
	1236-944MS	1236-944	Weldment - Chain Shield #2 Chain only - 24' Box		
	1236-946MS	1236-946	Weldment - Chain Shield #2 Chain only - 26' Box		
			Requires:		
			1200-302SS Carriage Bolt - 3/8" UNC x 1" SS		As Req'd
			1209-43 Lock Washer - 3/8" SS		
		1205-27 Nut - 3/8" UNC SS			
3	1000-37	1000-37	Seal Strips - STD (Specify Box Length)	2	
	1000-38	1000-38	Seal Strips - High Temp. (Specify Box Length)	2	
4	1205-86	1205-86	T-Nut (Specify Box Length)	As Req'd	
5	1200-086	1200-086	Button Head Socket Cap Screw - (Specify Box Length)	As Req'd	

TRAILER TAIL LIGHTS ASSY

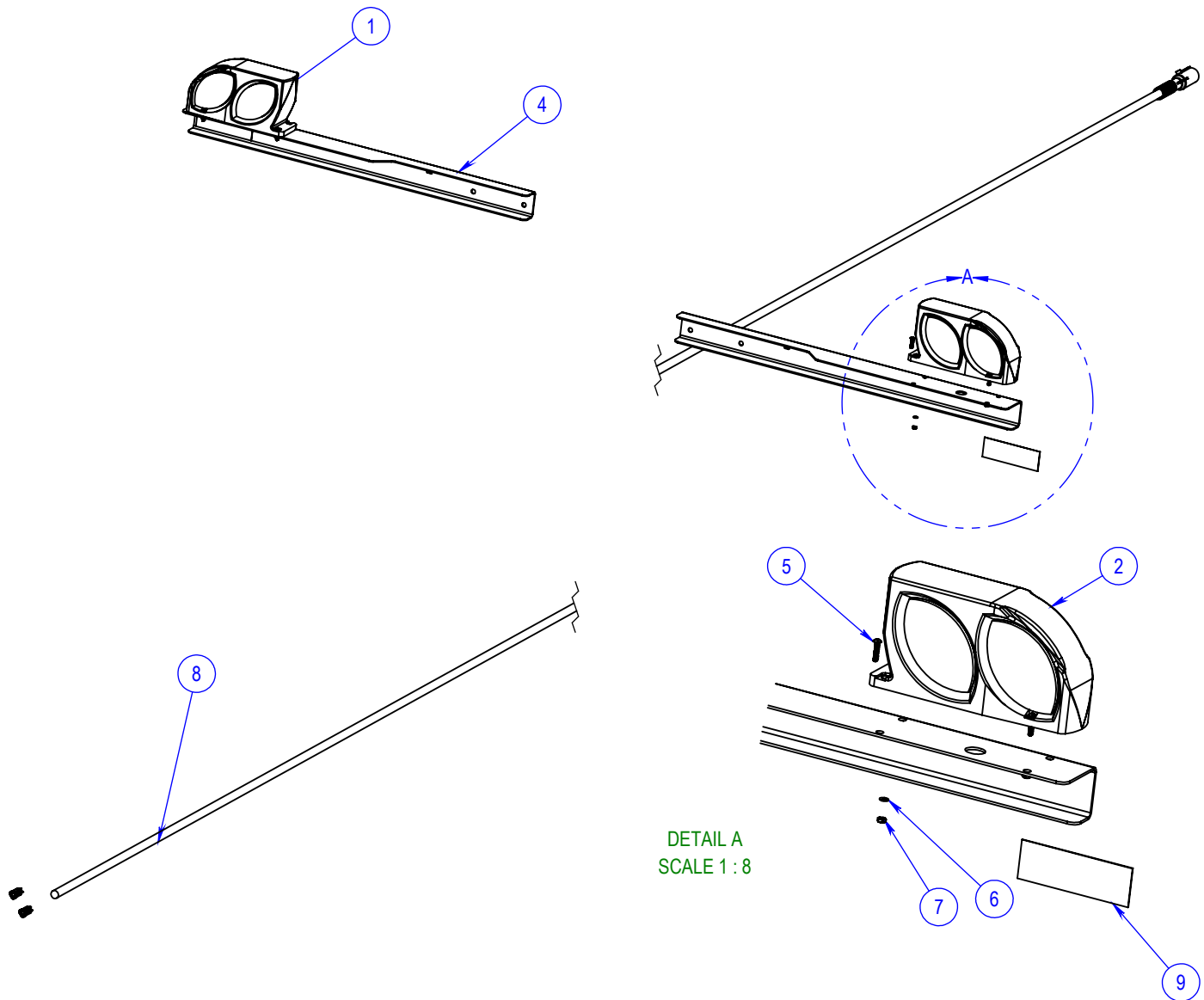

ITEM NO.	QTY.	PART NO.	DESCRIPTION
1	1	1214-273 R	Tail light, LED - RH Red / Dual Amber
2	1	1214-273 L	Tail light, LED - LH Red / Dual Amber
3	1	1238-80-521	TRAILER TAIL LIGHT BRACKET
4	1	1238-80-521-L	TRAILER TAIL LIGHT BRACKET
5	8	1200-021	SCREW, FLANGE RND HEAD, 10 - 32 X 1"
6	8	1209-19	FLATWASHER, 10-32
7	8	1205-256	LOCKNUT, TOP 10-32 SS
8	1	1223-754	TRAILER TAIL LIGHT EXTENSION CABLE
9	2	1238-80-523	TAPE, RED REFLECTOR

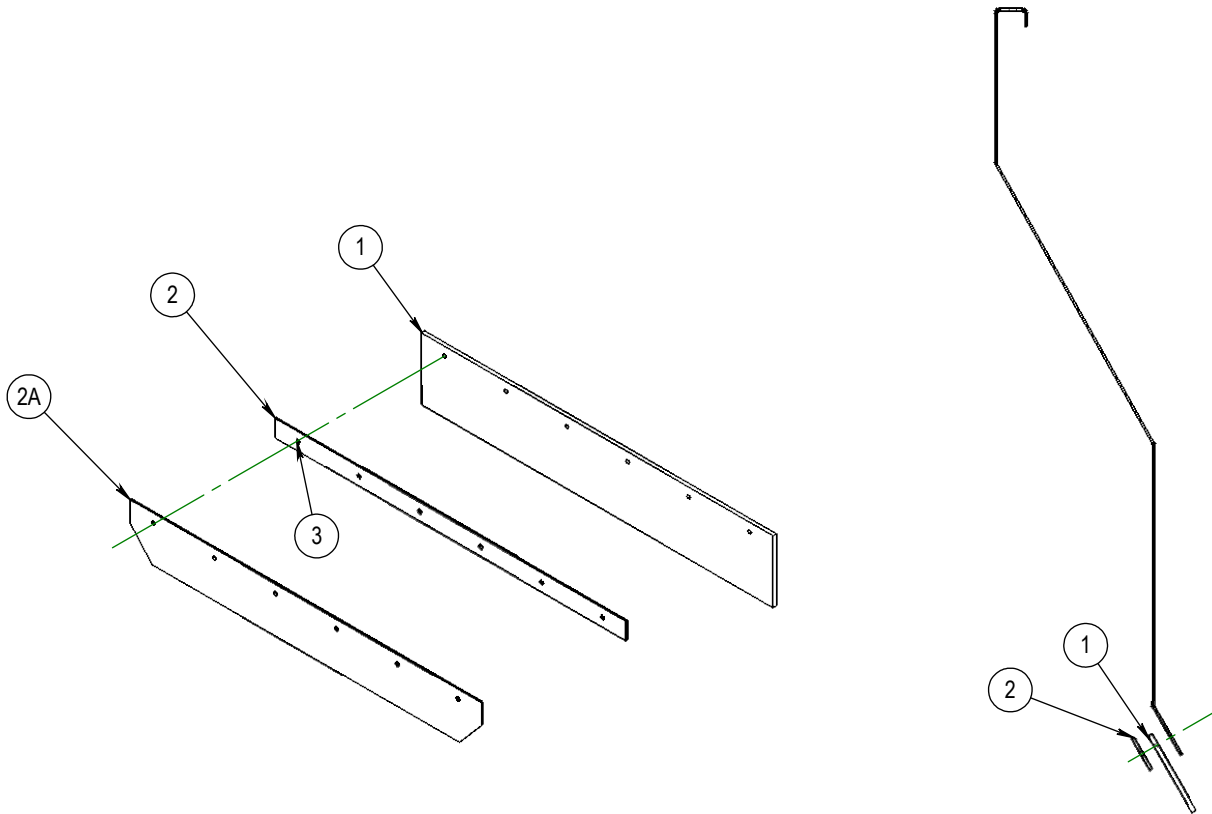

FRONT BELT SEALER

<u>ITEM</u>	<u>PART NO.</u>	<u>DESCRIPTION</u>	<u>QTY</u>
1	70-053	Front Belt Sealer Strip	1
	70-053-1	Front Belt Sealer Strip - High Temp	
	70-053-2	Front Belt Sealer Strip - Straight Chain	
2	70-089	Back Plate For Units w/Belt Over Chain	1
2A	70-089-1	Back Plate For Units w/Straight Chain Only	1
3	1200-202	(6) Hex Head Cap Screw - 1/4" UNC x 1" S/S	
	1209-22	(6) Lock Washer - 1/4" S/S	
	1205-11	(6) Nut - 1/4" UNC S/S	

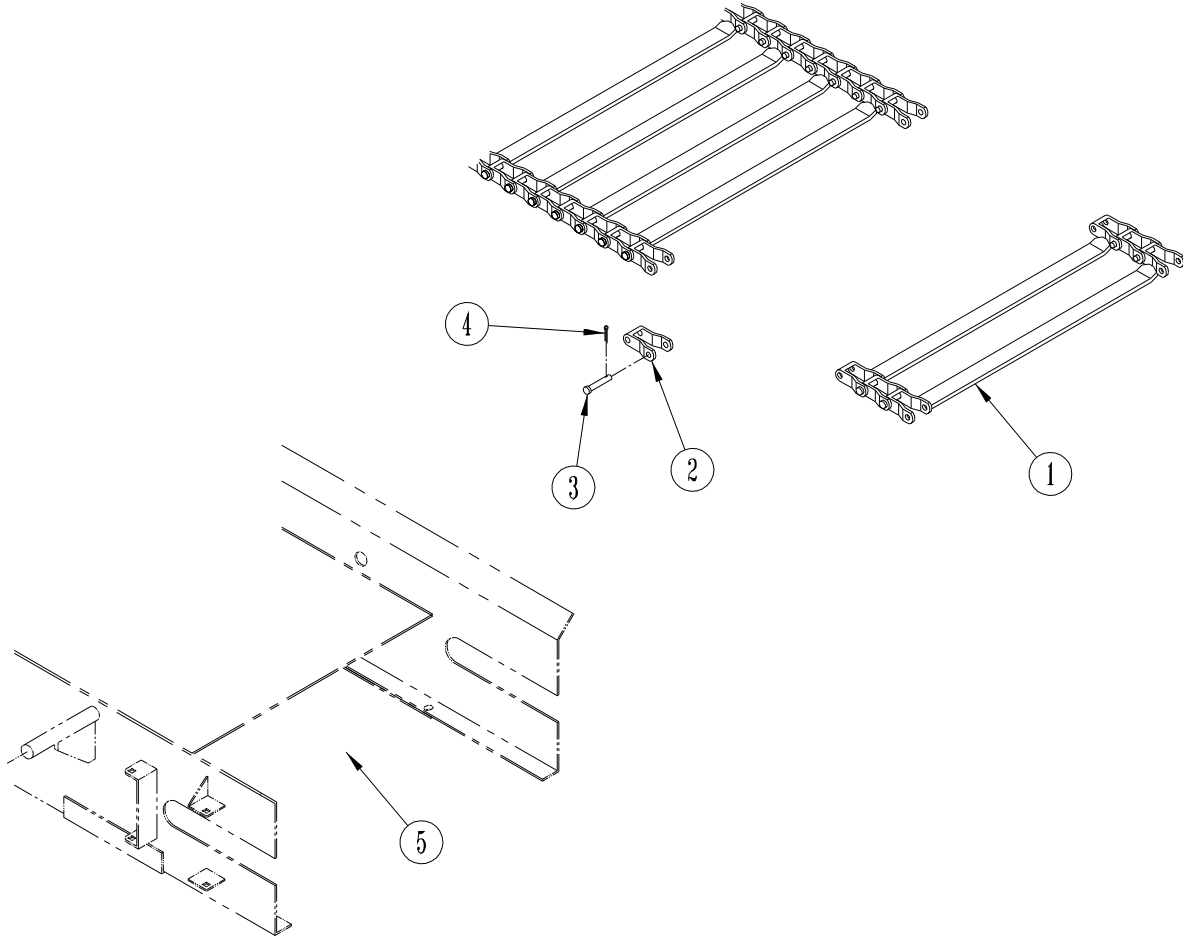

STRAIGHT CHAIN

ITEM	PART NO.	DESCRIPTION	QTY.
1	1236-907	Weldment - Crossbar	As Req'd
2	1234-901	Link - Pintle Chain	As Req'd
3	1234-902	Pin - Pintle Chain	As Req'd
4	1234-903	Cotter Pin	As Req'd
	1236-9XX	Assembly - #2 Straight Chain - Bar every other link (Specify Box Length)	As Req'd
	1236-9XX	Assembly - #3 Straight Chain - Bar every link (Specify Box Length)	As Req'd
5	1236-904AR	Conveyor Bed Extension Abbrasive resistant mat'l (Req'd on all Straight Chain Units Only)	1
5	1236-904SS	Conveyor Bed Extension Stainless Steel mat'l (Req'd on all Straight Chain Units Only)	1

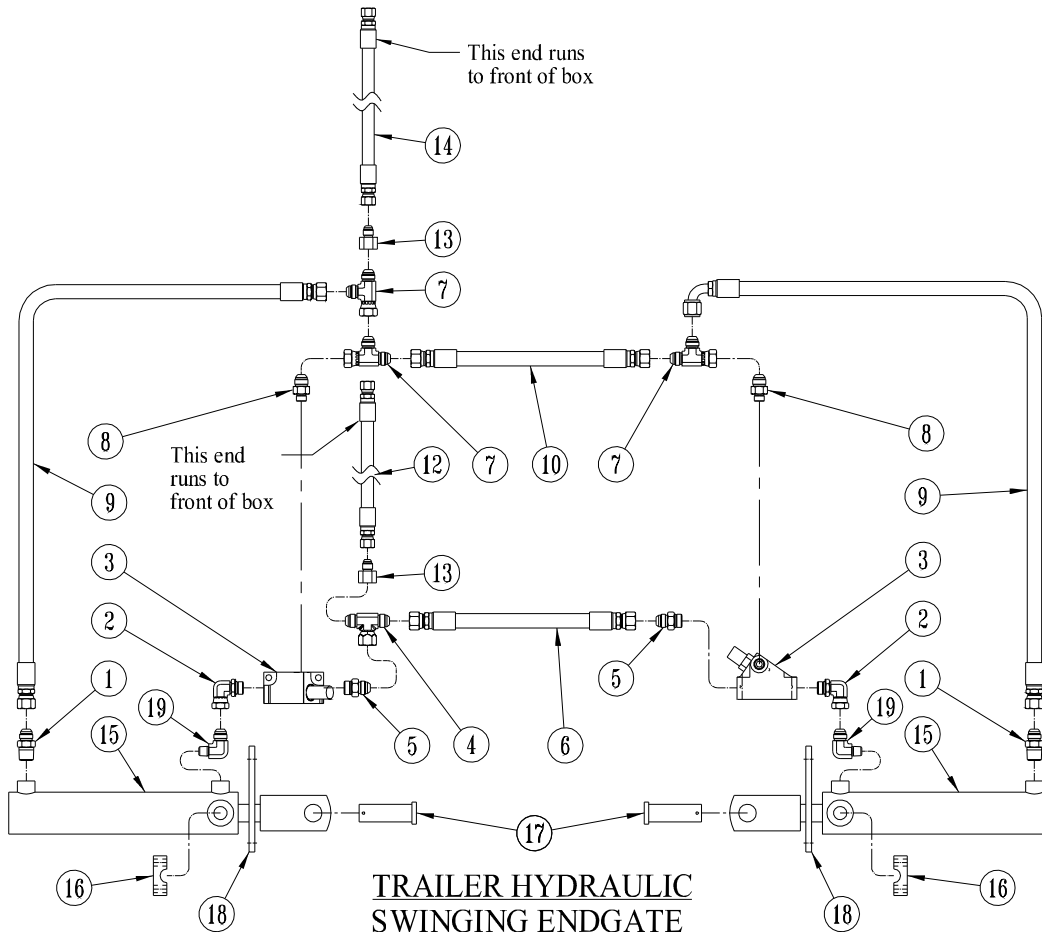

ITEM	PART NO.	DESCRIPTION	QTY
1	1202-1001	Adapter - Straight	2
2	1202-2094	Adapter - Elbow	2
3	1211-98	Valve Body	2
4	1202-285	Adapter - Tee	1
5	1202-1076	Adapter - Straight	2
6	1207-703	Hose Assembly	1
7	1202-3014	Adapter - Tee	3
8	1202-10750	Adapter - Straight	2
9	1207-701	Hose Assembly	1
10	1207-702	Hose Assembly	1
11			
12	1207-704	Hose Assembly - Cylinder Extend	1
13	1202-1029	Adapter - Straight	2
14	1207-705	Hose Assembly - Cylinder Retract	1
15	1100-150	Hyd. Cylinder	2
16	1100-150C	Clamp - Trunnion	4
	1200-303SS	Requires: (2) Hex Head Capscrew - 3/8 UNC x 1-1/4 SS	
	1209-43	(2) Lock Washer - 3/8" SS	
17	1236-651SS	Pin - Hyd. Cylinder	2
	1200-2049	Requires: (1) Hex Head Capscrew - 1/4 UNC x 1-1/2 SS	
	1205-501	(1) Lock Nut - 1/4 UNC SS	
		Per Pin	
18	1100-150S	Seal Strip - Cylinder Rod	2
	1200-202	Requires: (3) Hex Head Capscrew - 1/4" UNC x 1" SS	
	1209-25S	(3) Flat Washer - 1/4" SS	
	1209-22	(3) Lock Washer - 1/4" SS	
	1205-11	(3) Nut - 1/4" UNC SS	
		Per Seal Strip	
19	1202-1041	Adapter - Elbow	2

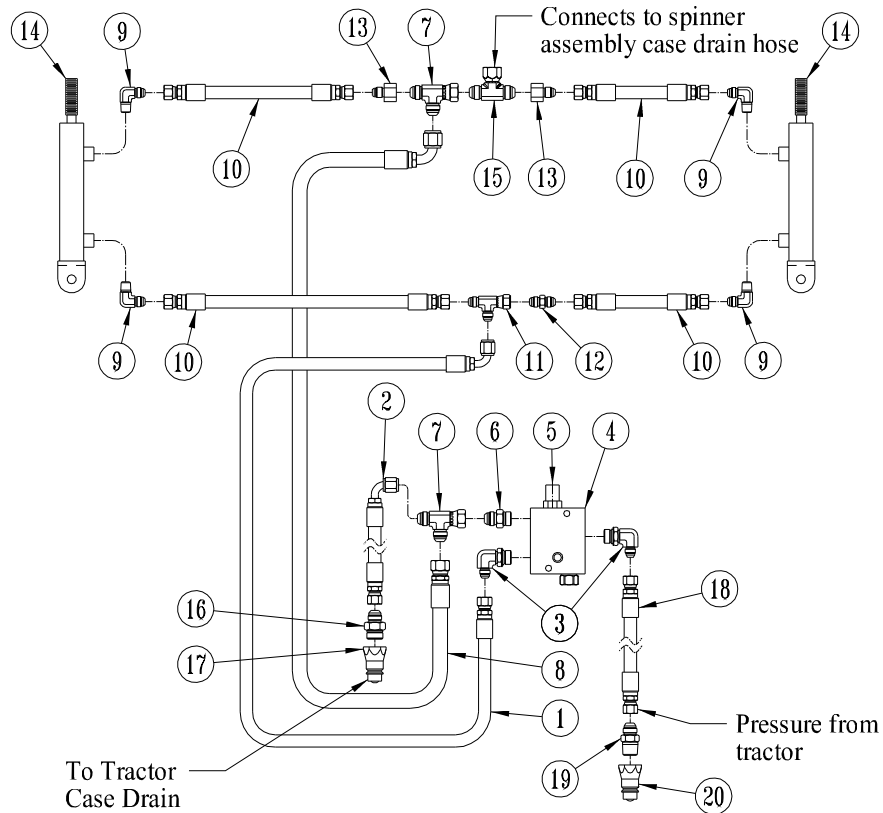

TRAILER HYDRAULIC BRAKES

ITEM	PART NO.	DESCRIPTION	QTY
1	1207-715	Hose Assembly	1
2	1207-716	Hose Assembly	1
3	1202-2020	Adapter - Elbow	2
4	1222-210	Valve Body Requires: 1200-257 (2) Hex Head Capscrew - 5/16 UNC x 2-1/2 1209-31 (2) Lock Washer - 5/16 1205-13 (2) Nut - 5/16 UNC	1
5	1222-21	Cartridge - Valve	1
6	1202-1076	Adapter - Straight	1
7	1202-3014	Adapter - Tee	2
8	1207-717	Hose Assembly	1
9	1202-1044	Adapter - Elbow	4
10	1207-718	Hose Assembly	4
11	1202-3012	Adapter - Tee	1
12	1202-00	Adapter - Straight	1
13	1202-1029	Adapter - Straight	2
14	1100-10S	Hydraulic Cylinder Requires: 1205-52 (1) Nut - 5/8 UNF 1200-325 (1) Hex Head Capscrew - 7/16 UNC x 2 1205-29 (2) Nut - 7/16 UNC 1209-50 (1) Flat Washer - 7/16 1208-034 (2) Pin Per Cylinder	2
15	1202-285	Adapter - Tee	1
16	1202-1076	Adapter - Straight	1
17	1202-8433	Quick Coupler	1
18	1207-720	Hose Assembly	1
19	1202-1073	Adapter - Straight	1
20	1202-8432	Quick Coupler	1

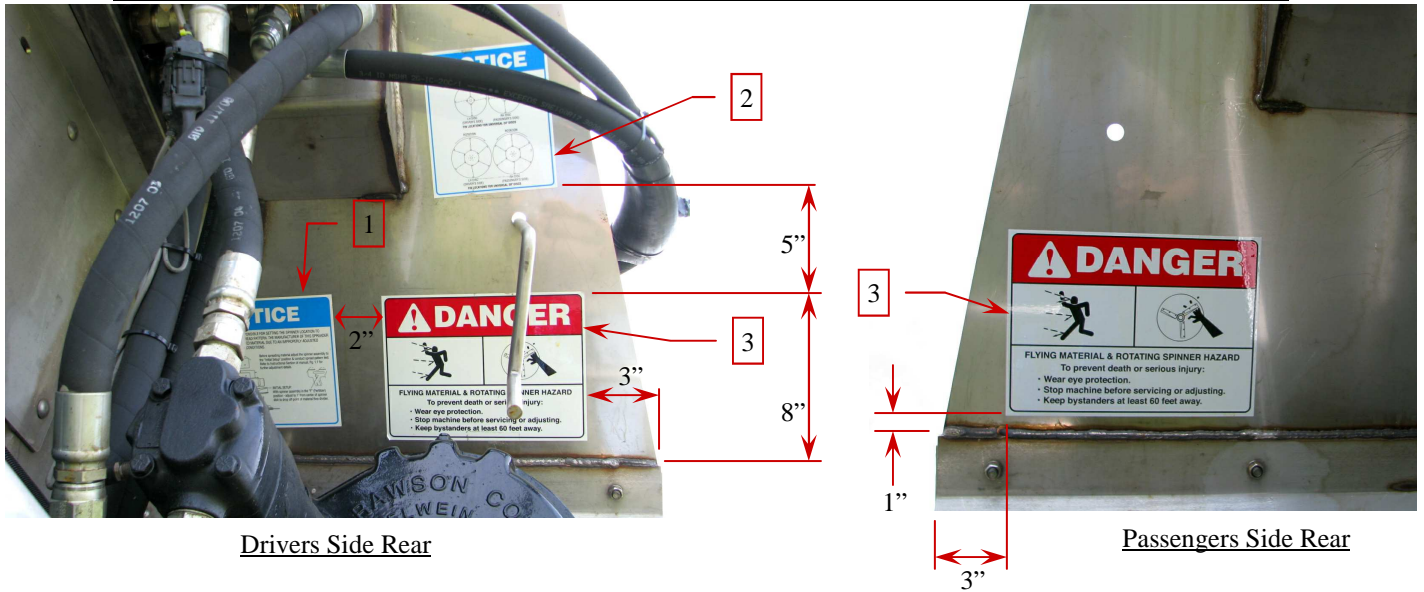

Drivers Side Rear

Passengers Side Rear

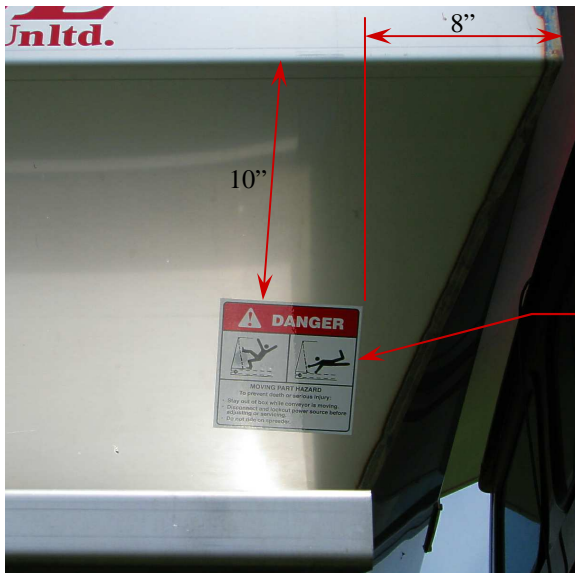

Passengers Side Front



Drivers Side Front

Safety Decals

<u>ITEM</u>	<u>PART NO.</u>	<u>DESCRIPTION</u>	<u>QTY.</u>
1	1234-050	Decal - Spinner Disc Location	1
2	1234-051	Decal - Fin Location on Universal Disc	1
3	1234-052	Decal - Flying Material	2
4	1234-053	Decal - To Avoid Injury or Machine Damage	1
5	1234-054	Decal - Moving Part Hazard	2

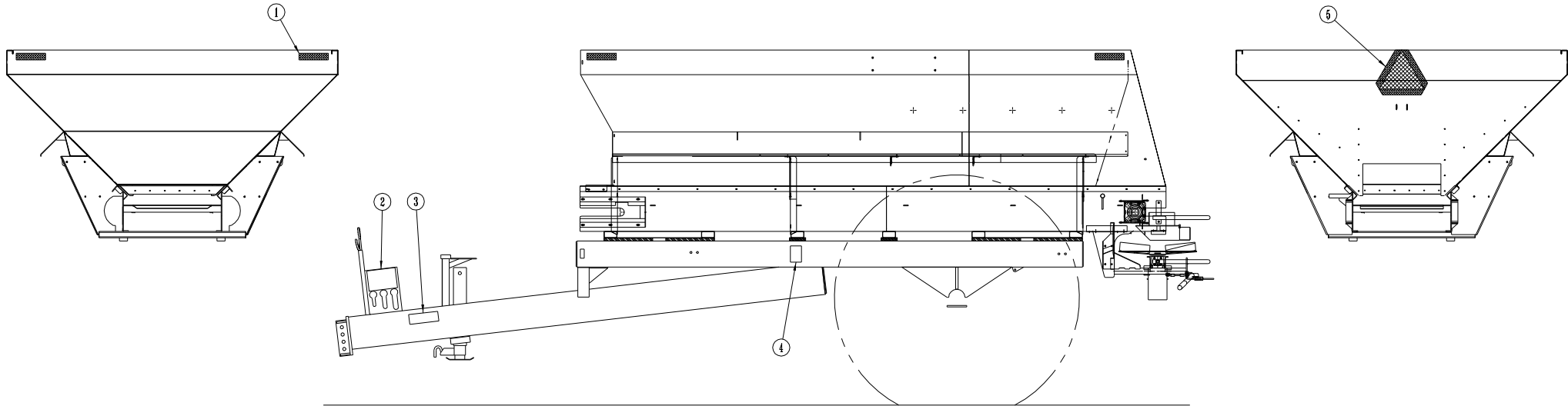

TRAILER DECAL LOCATIONS

ITEM NO.	PART NO.	DESCRIPTION	QTY.
1	1238-51	Yellow Reflective Tape	6
2	1238-48	Decal - Notice, Hose Marking	1
3	1238-49	Decal - Warning, Rising or Falling Tongue	1
4	1238-47	Decal - Notice, 10 Bolt Torque Spec	1
5	1238-50	Decal - Slow Moving Vehicle	1

OPTIONAL 12" H SS BOX EXTENSIONS FOR 102" W BOX

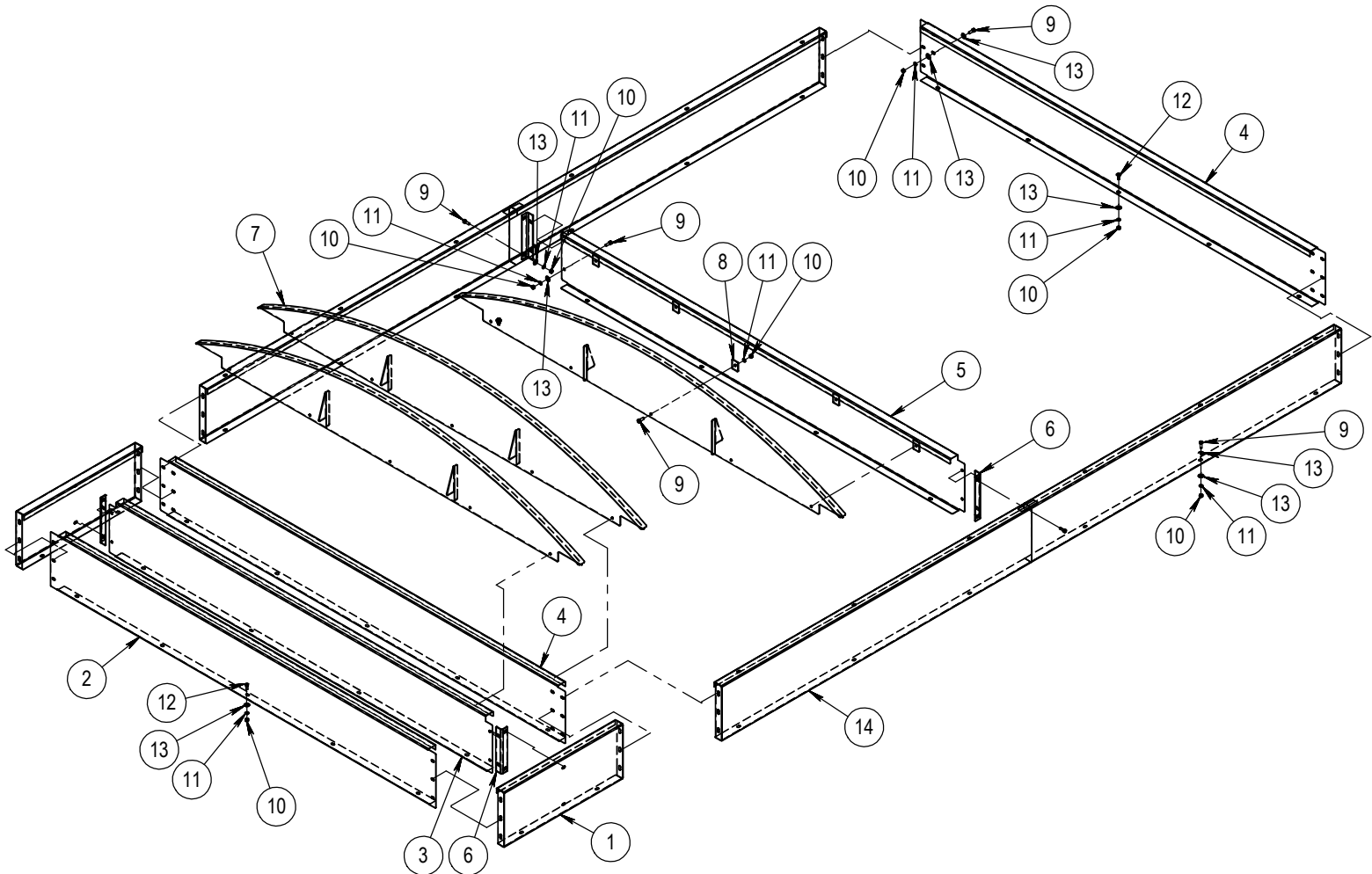

ITEM NO.	PartNo	DESCRIPTION	QTY.
1	1239-15205	12" TRI-FORCE BIN EXTENSION SIDE PANEL WELDMENT	2
2	1239-15305	12" HIGH TRI-FORCE REAR EXTENSION	1
3	1239-15405	12" HIGH TRI-FORCE BIN CENTER EXTENSION	1
4	1234-148	12" HIGH FRONT & REAR EXTENSIONS	2
5	1234-1520	12" HIGH CENTER EXTENSION	1
6	1234-1530	BRACKET FOR 12" HIGH EXTENSIONS	As Req'd
7	1237-18W	DF/TF/QF Divider Extension Weldment for use with 12" High Tarp	As Req'd
8	1234-942	BOARD EXTENSION CLIP	As Req'd
9	1200-3011	Hex Head Capscrew - 3/8" UNC x 1" SS	As Req'd
10	1205-27	Nut - 3/8" UNC SS	As Req'd
11	1209-43	Lock Washer - 3/8" SS	As Req'd
12	1200-302SS	Carriage Bolt - 3/8" UNC x 1" SS	As Req'd
13	1209-41	Flat Washer - 3/8" SS	As Req'd
14	1234-XXX	12" HIGH SIDE BOX EXTENSION (SPECIFY BOX LENGTH)	2